

TABLE OF CONTENTS

INTRODUCTION pages 1 - 5



power pumps

Index.....	1
Company Overview	2-3
Safety Tips	4-5



cylinders

Introduction	6 - 7
Proper Size and Selection	8 - 9
Spring Return	R Series 5-100 Tons..... 10 - 11
Spring Return	RLS Series 10-100 Tons.....12
Spring Return	RFS Series 5-150 Tons.....13
Pull Cylinder S/A	RP Series 2-5 Tons.....14
Pull Cylinder D/A.....	RDP Series 10-100 Tons.....15
Center Hole S/A.....	RC Series 12-100 Tons.....16
Center Hole D/A	RCD Series 30-500 Tons.....17
Load Return	RLR Series 30-1000 Tons..... 18 - 19
Locknut Load Return	RLN Series 30-1000 Tons..... 20 - 21
Double Acting	RDA Series 10-1000 Tons..... 22 - 23
Pancake Locknut.....	CLP Series 60-500 Tons.....24
Steel Cylinder Accessories.....	25
Alum. Spring Return	RAS Series 30-150 Tons.....26
Alum. Locknut	RAL Series 50-150 Tons.....27
Alum. S/A Center Hole	RAC Series 30-60 Tons.....28
Alum. D/A Center Hole	RACD Series 30-150 Tons.....29



hand pumps

Introduction	30 - 31
Proper Size & Selection	32 - 33
Compact Steel.....	34
Lightweight Aluminum	35
Heavy Duty.....	36
Special Application.....	37
Ultra High Pressure Aluminum	38
Ultra High Pressure Accessories.....	39
Pump & Cylinder Sets - Steel & Aluminum.....	40 - 41

Introduction	42 - 43
Proper Size & Selection	44 - 45
G1 Series Electric.....	46 - 47
G3 Series Electric.....	48 - 49
G4 Series Electric.....	50 - 51
G5 Series Electric.....	52 - 53
G6 Series Electric.....	54 - 55
G5 Series Air.....	56 - 57
G4 Series Gas	58 - 59
G6 Series Gas	60 - 61
G Series Accessory Kits.....	62 - 63
Compact Pumps - Air over Hydraulic.....	64 - 65



accessories

Introduction	66 - 67
Proper Selection	68 - 69
2 & 3 Way Control Valves	70
4 Way Control Valves.....	71
In Line System Valves.....	72
High Pressure Manifolds.....	73
1/4" NPTF Couplers	74
3/8" NPTF Couplers	75
NPTF Fittings and Oil.....	76
Analog & Digital Gauges	77
High Pressure Hoses	78 - 79



bolting

Introduction	80 - 81
Proper Size & Selection	82 - 83
G1 Series Lightweight Bolting Pump	84
G3 Series Heavy Duty Bolting Pump	85
G5 Series Heavy Duty Bolting Pump	86
G5 Series Heavy Duty Air Bolting Pump	87
WT Series Torque Wrenches - Square Drive	88
Torque Wrenches - Square Drive Accessories	89
WX Series Torque Wrenches - Low Clearance	90 - 91



presses

Introduction	114 - 115
Proper Size & Selection	116 - 117
H-Frame Bench 10 & 15 Tons	118
H-Frame 10 Tons	119
H-Frame 25 & 30 Tons	120
H-Frame 55 Tons	121
H-Frame 100 Tons	122
H-Frame 150 - 200 Tons	123



lifting jacks

Introduction	92 - 93
Proper Size & Selection	94 - 95
HJ Series Hand Jacks	96
TJH Series Toe Jacks - Heavy Duty	97
B Series Air Lifting Bags	98 - 99
Air Bag Accessories	100 - 101



mechanical

Introduction	124 - 125
Proper Size & Selection	126 - 127
RJ Series Ratchet Jacks	128 - 129
CR Series Reel Jacks	130 - 131
CJ Series Rack Jacks	132
LPC Series Rack Jacks	133
Push / Pull Jacks	134
JJ Series Super Jacks	135
SJ Series Screw Jacks	136
Screw & Cap Assemblies	137
44 Series Tank Jacks	138
SER Series Loadbinder Jacks	139
PJ Series Planer Jacks	140
S Series Spreader Jacks	141
RS Series Roof Support	142 - 143
RS Series Roof Support Base	144 - 145
SE & BE Series Trench Braces	146 - 147
Lever Bar & Accessories	148



hydraulic tools

Introduction	102 - 103
Proper Size & Selection	104 - 105
Single Acting Punch - 35 Tons	106 - 107
S Series Hydraulic Spreaders	108
SF Series Hydraulic Spreaders - 5 Tons	109
NS Series Nut Splitters	110
Maintenance Kit	111
Maintenance Kit - Components	112 - 113

MISCELLANEOUS

System Arrangements	149
Conversion Chart	150
Notes	151
Notes	152

All Simplex Product Dimensions are subject to change without notice. Please consult your Simplex Representative for verification of critical specifications, or email: info@tksimplex.com

All Simplex Products are warranted against defects in material and workmanship. Any Simplex Product proven defective will be repaired or replaced at no charge. Contact your authorized Simplex Service Center or visit the Simplex Support Center at: www.tksimplex.com



1. Choose The Right Ram.



You must know the weight of what you intend to lift and choose a ram with at least 20% more capacity. Be aware of possible load shift requiring more capacity at any particular lifting point.

2. Inspect All System Components.

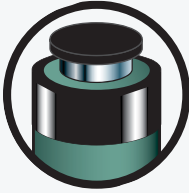

Check each component before you set up your hydraulic system. Do not use damaged or worn components. Turn them in for repair or replacement.

3. Safety Instructions.



Read all warning labels and instructions. Operating instructions must be understood before using equipment. Never remove labels from equipment. Replace missing, worn, or damaged labels. Always wear safety goggles and protective clothing when using hydraulic equipment.

4. Each Jack Or Ram Must Be Fully Supported At The Base.

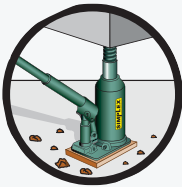

Every jack or ram, whether used individually or in a system, should be completely supported on a solid, firm, non-sliding foundation capable of supporting the load.

5. Fill Oil Reservoirs With Cylinder Retracted.



Only fill pump to recommended level, and fill only when connected cylinder is fully retracted.

6. Know How Your Hydraulics Work.

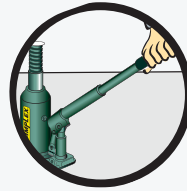

Do not use extensions or cheater bars on hydraulic jacks or hand pumps to raise a load.

7. Center The Load On The Lifting Point.

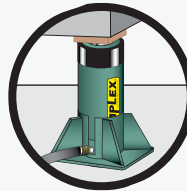

The load must be centered on the ram, or equally distributed on multiple rams. Off center loading can result in the ram slipping out and loss of the load.

8. When Using Multiple Rams, Distribute The Load Evenly.

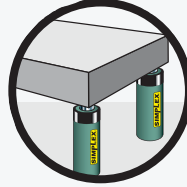

For multiple ram lifts, you must be able to determine the location and number of lifting points that will allow the load to be evenly distributed to all the rams. Size, center of gravity, and load geometry must be considered in order to correctly determine load balance.

9. Block Or Crib Your Load As It Raises.

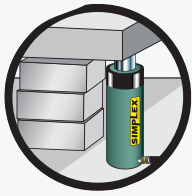

Place blocking or cribbing under the loads as you raise it. Each time you raise it higher, insert more blocking. Position yourself in a manner that will keep you clear of the load, and will not allow your hands or other body parts between the load and the cribbing.

10. Do Not Use Rams As Permanent Supports.

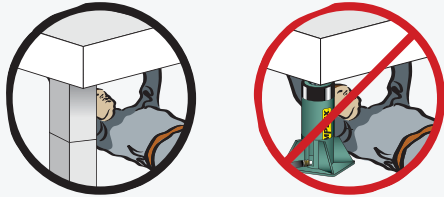

Hydraulic rams are not meant to be used as permanent supports, but are designed to lift and lower. If you need to hold the load for any length of time, cribbing or Simplex locknut cylinders should be used.

11. Hydraulic Connections.

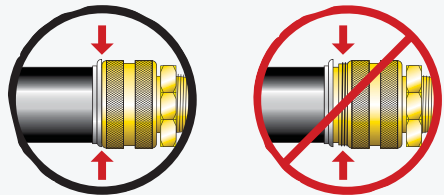

When making connections with quick couplers, make sure the couplings are fully engaged. Threaded connections such as fittings, gauges, etc. must be securely tightened and leak free. Never use excessive tightening force that may distort the fittings or strip the thread profile.

12. Avoid Extreme Heat Or Weld Splatter.

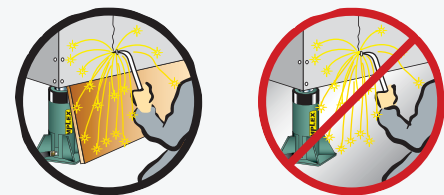

Weld splatter will damage plunger rods and hoses. Hydraulic fluid can ignite if vaporized or exposed to high temperatures.

13. Hydraulic Disconnections.



Never attempt to disconnect hydraulic hoses, fittings or couplers under pressure. Unload the ram, open the release screw on the hand pump and shift or open all hydraulic controls several times. If system includes a gauge, double check the gauge to insure pressure has been completely released.

14. Do Not Carry Or Drag Pumps And Rams By Their Hoses.



Dragging or carrying rams or pumps by a connected hose can damage the couplers and hoses. Using damaged couplers and hoses can be dangerous.

15. Keep Hydraulic Hoses Free Of Obstructions.

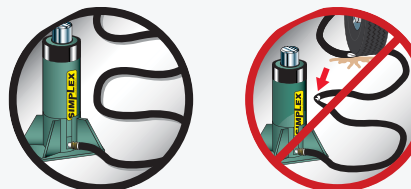

Do not drop sharp or heavy objects on hose. Keep hose out of heavy traffic areas. This will cause internal damage to hose wire strands. Applying pressure to a damaged hose may cause it to rupture. Avoid sharp bends and kinks when routing hydraulic hoses.



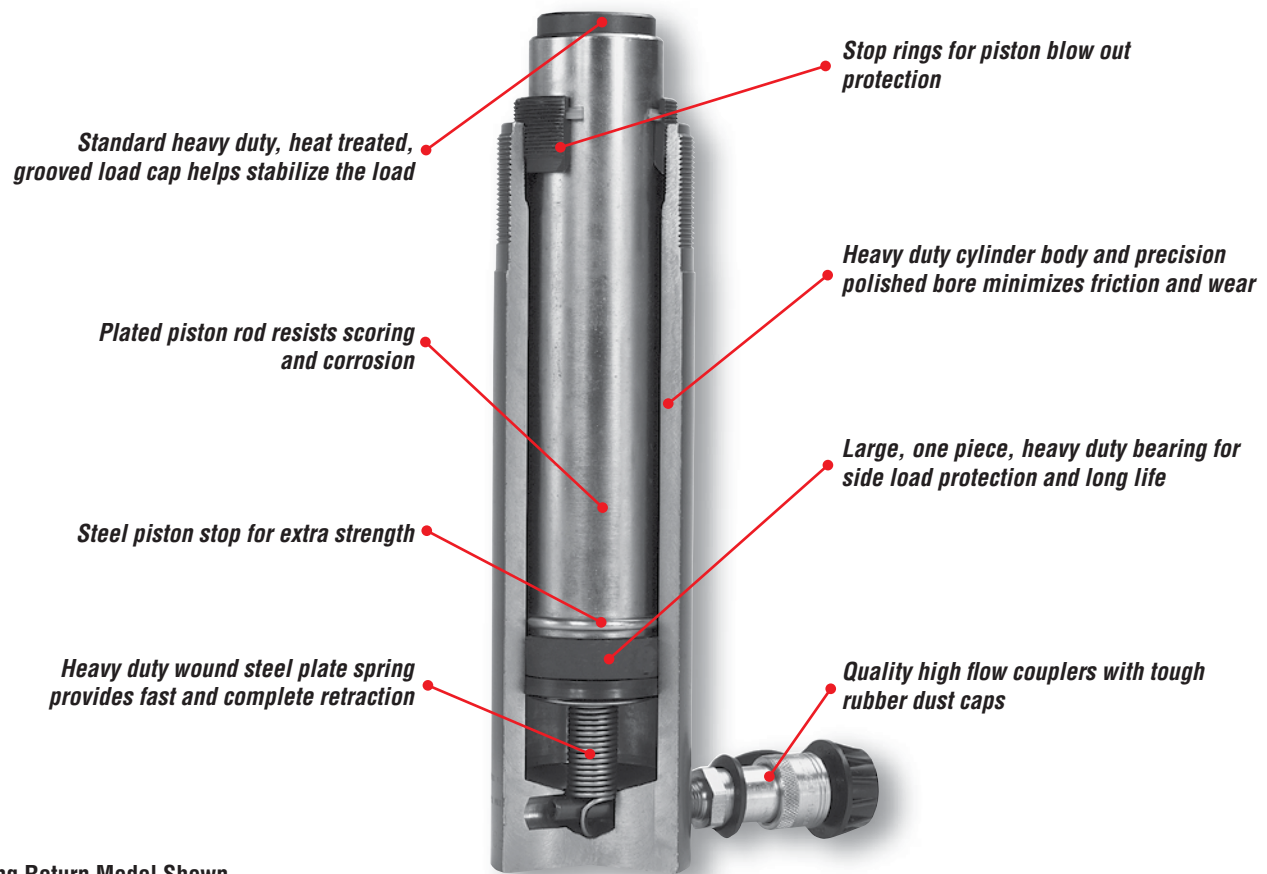

Spring Return Model Shown

PRODUCT LINE OVERVIEW

► **Wide Variety**

Simplex offers the widest selection of cylinder styles, tonnages and strokes to match your specific requests.

► **Built for Rugged Industrial/Construction Use**

All Simplex cylinders meet ANSI/ASME B30.1 SAFETY STANDARDS. Stop rings, plated pistons and heavy duty construction provide trouble free operation and long life.

► **Standard Design Elements**

Cylinders are designed for 10,000 psi operating pressure which offers a smaller footprint and greater force.

► **Versatile Fixturing**

Threaded collars and internal plunger threads withstand full loading for maximum flexibility in fixturing.

► **Piston Blow-Out Protection**

All Simplex cylinders (*excluding CLP Series*) incorporate a positive piston stop to limit piston travel at the end of the stroke, and allows the cylinder to be operated at full stroke. Piston stops add strength and safety to your cylinder.

► **Protection from Contamination**

Polyurethane wipers clean the rod surface during retraction, protecting the inner cylinder assembly from dirt, moisture and other contaminants.

Single Acting



Single acting cylinders are hydraulically driven in one direction. These cylinders are used in many general purpose applications when retract speed is not a requirement. This cylinder type requires a pump source with a single acting valve for proper operation.

Both Spring Return and Load Return cylinders are constructed and operated in a similar manner, but function differently on the return.

- ▶ *Spring Return cylinders are hydraulically extended, but utilize a spring for retraction assistance.*
- ▶ *Load Return cylinders are hydraulically extended and retracted by the load or other external forces.*
- ▶ *Simplex 3 Way, 3 Position Suc-O-Matic valve can draw hydraulic oil out of any single acting cylinder. In the retract position, the valve generates enough suction to fully retract any single acting load return cylinder automatically.*

Double Acting



Double acting cylinders are hydraulically driven in both directions. These cylinders are used in many general purpose applications where retraction speed is required or the mechanical forces required for return is not available. This cylinder type requires a pump source with a 4 way valve for proper operation.

- ▶ *Oil entering the advance port exerts pressure on the bottom plunger face raising the piston upward and oil on the retract side exits the retract port.*
- ▶ *When oil is pumped into the retract port, it exerts pressure on the top plunger face causing the plunger to retract and oil exits the advance port.*
- ▶ *A safety relief is installed on the retract side of all Simplex double acting cylinders to prevent over-pressurization in the event the retract line has been blocked.*

Center Hole



Center hole cylinders are available in both single and double acting styles. These cylinders are primarily used for pushing and pulling applications. Both styles have a center tube that allows a rod or cable to pass through the cylinder and assist in tensioning / pulling applications.

Both single acting and double acting center-hole cylinders are constructed and operated in a similar manner to their standard counterparts.

- ▶ *Single acting center-hole cylinders utilize a spring for retraction. This cylinder type requires a pump source with a 3 way valve for proper operation.*
- ▶ *Double acting center-hole cylinders are hydraulically extended and retracted. This cylinder type requires a pump source with a 4 way valve for proper operation.*

Force & Speed Calculations

Flow: Created by the pump source.

Pressure: Generated by resistance to flow and pressure from the pump source. This resistance is usually the result of a load.

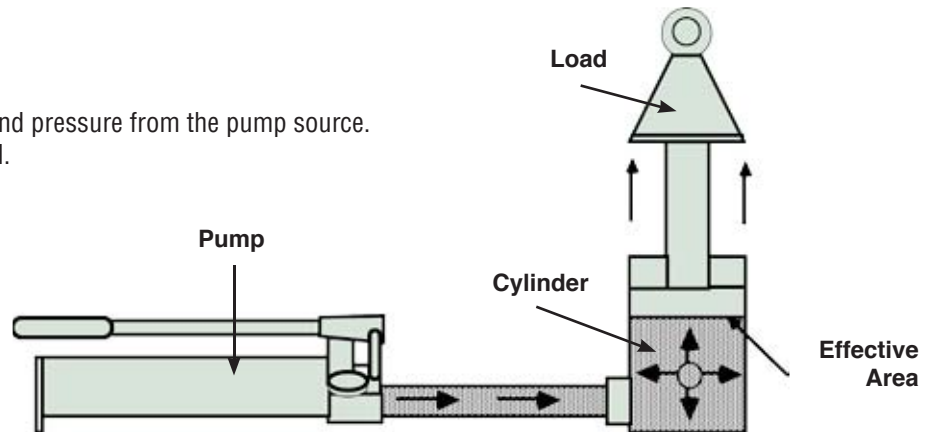

Force: The amount of force a hydraulic cylinder can generate is equal to hydraulic pressure times the effective area of the cylinder. **(Effective area is the surface area of the piston face in square inches.)** For multiple cylinder systems, multiply the effective area times the number of cylinders times pressure to determine system force.

Formula for Calculation of Output Force:

$$\frac{\text{psi} \times \text{Cylinder Effective Area} \times \text{No. of Cylinders}}{2,000} = \text{TONS}$$

Speed: When using a “power pump” the speed at which your cylinder will lift is determined by dividing the pump’s flow by the cylinder’s effective area.

Formula for Calculation of Lifting Speed:

$$\frac{\text{Pump Flow Per Minute}}{\text{Cylinder Effective Area} \times \text{No. of Cylinders}} = \frac{\text{in./min.}}{\text{Piston Travel}}$$

Simplex Cylinders At A Glance Chart

Cylinder Series	Description/Applications	Cylinder Type	Plunger Type	Capacity (Tons)	Strokes (in)	Page (#)	
R	General Purpose Spring Return For Fast Retraction	Single Acting	Solid	5 - 100	.62 - 14.38	10-11	
RAS	Lightweight, General Purpose Spring Return			30 - 150	2 - 10	26	
RAL	Lightweight Load Holding Locknut Spring Return			50 - 150	2 - 10	27	
CLP	Low Profile Locknut			60 - 500	1.77 - 1.97	24	
RAC	Lightweight Center Hole Spring Return			30 - 60	3 - 6	28	
RACD	Lightweight Center Hole	Double Acting	Center Hole	30 - 150	2 - 10	29	
RLS	Low Height Spring Return	Single Acting	Solid	10 - 100	1.5 - 2.25	12	
RFS	Very Low Height Spring Return			5 - 150	.44 - .62	13	
RP	Pull Cylinder Spring Return			2 - 5	5 - 5.5	14	
RLN	Mechanical Load Holding / Locknut Load Return			30 - 1,000	2 - 12	20-21	
RLR	Single Acting Load Return			30 - 1,000	2 - 12	18-19	
RC	Single Acting Center Hole			Center Hole	12 - 100	.31 - 6.13	16
RCD	Double Acting Center Hole				30 - 646	3 - 10	17
RDP	Double Acting Pull Cylinder	Double Acting	Solid	10 - 100	6	15	
RDA	Double Acting Controlled Retraction / Fast Cycling			10 - 1,000	2 - 24	22-23	

STEEL CYLINDERS

R Series - Spring Return

SIMPLEX



R556 Shown

Capacity ▶ 5 - 100 tons
Stroke ▶ .62 - 14.38 in.
Maximum Pressure ▶ 10,000 psi

- ▶ HD internal spring for fast retract assistance.
- ▶ Heat treated load caps are standard.
- ▶ Stop ring for piston blow-out protection.
- ▶ Plated piston resists scoring & corrosion.
- ▶ High flow couplers are plated to resist corrosion.
- ▶ Rod wiper protects inner cylinder from dirt.

HOSES - pages 78 - 79



Heavy duty and thermo plastic hydraulic hoses to meet your requirements and safety factor.

POWER PUMPS - pages 43 - 65



Simplex offers a wide variety of lightweight power pumps to fit any application.

GAUGES - page 77



Improve your system visibility and safety by adding an inline hydraulic gauge to your circuit.

THINK SAFETY



Please refer to pages 4&5 for a complete list of safety tips and recommendations.

MANIFOLDS - page 73



The ideal solution in obtaining precise control when operating multiple cylinders.

This R10010 is used to press the drive shaft into a large industrial fan during standard maintenance. When combined with a Simplex power pump, this job was completed quickly and safely. ▼



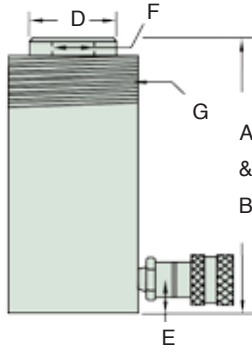

* R50 Base Mounting hole 7/32 through x 23/64 "C" bore (1/4" depth).

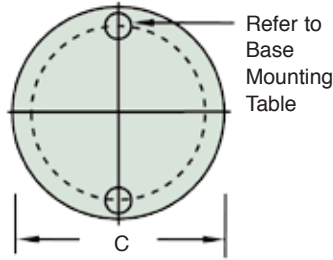

Standard Base Mounting Holes R51 through R10010 Cylinders

Model	Bolt Circle (in)	Thread (in)	Thread Depth (in)
5 Ton*	1	.25 - 20 UNC	.56
10 Ton	1.56	.31 - 18 UNC	.50
15 Ton	1.88	.38 - 16 UNC	.50
25 Ton	2.31	.5 - 13 UNC	.75
30 Ton	----	----	----
55 Ton	3.75	.5 - 13 UNC	.75
75 Ton	----	----	----
100 Ton	5.5	.75 - 10 UNC	1.00

Model	Cap. (Tons)	Stroke (in)	Oil Cap. Req'd (cu in)	Ram Bore Dia. (in)	Effect Area (sq.in.)	Pres. @ Cap. (psi)	A		B		C		D		E		F		G		Wgt. (lbs)
							Min. Height (in)	Ext. Height (in)	Body O.D. (in)	Piston O.D. (in)	Base to Port C/L (in)	Piston I.D. Thrds (in)	Piston Threads Depth (in)	Collar Threads (in)	Collar Threads Lgth (in)						
R50	5	0.62	0.6	1.13	0.99	10,000	1.62	2.24	2.62	1.00	0.75	----	----	----	----	----	----	----	----	2.5	
R51	5	1.13	0.99	1.13	0.99	10,000	4.37	5.50	1.5	1.00	0.75	.75 -- 16	0.75	1.5 -- 16	1.13	2.3					
R53	5	3.13	2.98	1.13	0.99	10,000	6.52	9.65	1.5	1.00	0.75	.75 -- 16	0.75	1.5 -- 16	1.13	3.3					
R55	5	5.13	4.97	1.13	0.99	10,000	8.52	13.65	1.5	1.00	0.75	.75 -- 16	0.75	1.5 -- 16	1.13	4.1					
R57	5	7.18	6.96	1.13	0.99	10,000	10.75	17.93	1.5	1.00	0.75	.75 -- 16	0.75	1.5 -- 16	1.13	5.3					
R59	5	9.18	9.07	1.13	0.99	10,000	12.83	22.01	1.5	1.00	0.75	.75 -- 16	0.75	1.5 -- 16	1.13	6.1					
R101	10	1.03	2.3	1.69	2.24	8,945	3.50	4.53	2.25	1.50	0.75	----	----	2.25 -- 14	1.13	4					
R102	10	2.19	4.18	1.69	2.24	8,945	4.78	6.97	2.25	1.50	0.75	1 -- 8	0.75	2.25 -- 14	1.13	5.1					
R104	10	4.19	9.2	1.69	2.24	8,945	6.78	10.97	2.25	1.50	0.75	1 -- 8	0.75	2.25 -- 14	1.13	7.2					
R106	10	6.00	13.7	1.69	2.24	8,929	9.78	15.78	2.25	1.50	0.75	1 -- 8	0.75	2.25 -- 14	1.13	9.8					
R108	10	8.00	17.89	1.69	2.24	8,929	11.78	19.78	2.25	1.50	0.75	1 -- 8	0.75	2.25 -- 14	1.13	12					
R1010	10	10.00	22.65	1.69	2.24	8,929	13.78	23.78	2.25	1.50	0.75	1 -- 8	0.75	2.25 -- 14	1.13	14					
R1012	10	12.00	26.84	1.69	2.24	8,929	15.78	27.78	2.25	1.50	0.75	1 -- 8	0.75	2.25 -- 14	1.06	15					
R1014	10	14.00	31.31	1.69	2.24	8,929	17.78	31.78	2.25	1.50	0.75	1 -- 8	0.75	2.25 -- 14	1.06	18					
R152	15	2.13	6.28	2.00	3.14	9,554	5.83	7.96	2.75	1.63	0.75	1 -- 8	1.00	2.75 -- 16	1.19	9					
R154	15	4.13	12.57	2.00	3.14	9,554	7.83	11.96	2.75	1.63	0.75	1 -- 8	1.00	2.75 -- 16	1.19	11					
R156	15	6.38	19	2.00	3.14	9,554	10.69	17.07	2.75	1.63	1.00	1 -- 8	1.00	2.75 -- 16	1.19	15					
R1510	15	10.38	31.4	2.00	3.14	9,554	14.69	25.07	2.75	1.63	1.00	1 -- 8	1.00	2.75 -- 16	1.19	21					
R1514	15	14.38	44	2.00	3.14	9,554	18.69	33.07	2.75	1.63	1.00	1 -- 8	1.00	2.75 -- 16	1.19	26					
R251	25	1.00	5.16	2.56	5.16	9,690	5.50	6.50	3.62	2.25	1.00	1.5 -- 16	1.13	3.31 -- 12	1.93	13					
R252	25	2.00	10.31	2.56	5.16	9,690	6.50	8.50	3.62	2.25	1.00	1.5 -- 16	1.13	3.31 -- 12	1.93	14					
R254	25	4.00	20.63	2.56	5.16	9,690	8.50	12.50	3.62	2.25	1.00	1.5 -- 16	1.13	3.31 -- 12	1.93	18					
R256	25	6.19	32.23	2.56	5.16	9,690	10.75	16.94	3.62	2.25	1.00	1.5 -- 16	1.13	3.31 -- 12	1.93	22					
R258	25	8.19	42.55	2.56	5.16	9,690	12.75	20.94	3.62	2.25	1.00	1.5 -- 16	1.13	3.31 -- 12	1.93	27					
R2510	25	10.19	52.86	2.56	5.16	9,690	14.75	24.94	3.62	2.25	1.00	1.5 -- 16	1.13	3.31 -- 12	1.93	31					
R2512	25	12.19	63.18	2.56	5.16	9,690	16.75	28.94	3.62	2.25	1.00	1.5 -- 16	1.13	3.31 -- 12	1.93	36					
R2514	25	14.19	73.49	2.56	5.16	9,690	18.75	32.94	3.62	2.25	1.00	1.5 -- 16	1.13	3.31 -- 12	1.93	39					
R308	30	8.25	53.6	2.88	6.49	9,245	15.25	23.50	4	2.25	2.25	1.5 -- 16	1.00	3.31 -- 12	1.93	40					
R552	55	2.00	22.08	3.75	11.04	9,960	6.94	8.94	5	3.13	1.38	----	----	5 -- 12	2.81	33					
R554	55	4.00	44.16	3.75	11.04	9,960	8.94	12.94	5	3.13	1.38	----	----	5 -- 12	2.81	42					
R556	55	6.19	69	3.75	11.04	9,960	11.06	17.25	5	3.13	1.38	----	----	5 -- 12	2.81	51					
R5513	55	13.25	146.3	3.75	11.04	9,960	18.26	31.51	5	3.13	1.38	----	----	5 -- 12	2.81	83					
R756	75	6.06	95.4	4.50	15.90	9,430	11.31	17.37	5.75	3.75	1.19	----	----	5.75 -- 12	1.75	65					
R7513	75	13.06	208	4.50	15.90	9,430	19.38	32.44	5.75	3.75	1.19	----	----	5.75 -- 12	1.75	130					
R1006	100	6.63	137	5.13	20.63	9,695	14.06	20.69	7	4.13	1.62	----	----	6.87 -- 12	1.75	90					
R10010	100	10.25	212	5.13	20.63	9,695	17.69	27.94	7	4.13	1.62	----	----	6.87 -- 12	1.75	110					

STEEL CYLINDERS

RLS Series - Low Profile Spring Return

SIMPLEX



Capacity▶ 10 - 100 tons
 Stroke▶ 1.5 - 2.44 in.
 Maximum Pressure▶ 10,000 psi

- ▶ Compact low-profile design.
- ▶ HD spring for fast retraction.
- ▶ Grooved plunger to stabilize the load.
- ▶ Stop ring for piston blow-out protection.
- ▶ Rod wiper protects inner cylinder from dirt.
- ▶ Plated piston to resist scoring & corrosion.

RLS201 Shown

Cylinders



GAUGES - page 77

Improve your system visibility and safety by adding an inline hydraulic gauge to your circuit.



IN-LINE VALVES - page 72

Maximize control and safety with our in-line valves.



POWER PUMPS - pages 43 - 65

Simplex offers a wide variety of lightweight power pumps to fit any application.

Simplex RLS Series provides the ideal fit and force required for most bridge lifting and pier cap maintenance jobs.▼

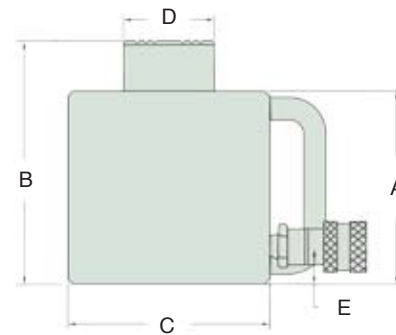

Model	Cap. (tons)	Stroke (in)	Oil Capacity Required (cu.in.)	Ram Bore Diameter (in)	Effect Area (sq in)	Pressure @ Capacity (psi)	A	B	C	D	E	Wgt. (lbs)
							Minimum Height (in)	Extended Height (in)	Body O.D. (in)	Piston O.D. (in)	Base to Port C/L (in)	
RLS101	10	1.5	3.4	1.68	2.24	8,940	3.47	4.97	2.75	1.5	.68	9
RLS201	20	1.75	7.8	2.38	4.43	9,030	3.87	5.62	3.62	2	.68	11
RLS302	30	2.44	15.8	2.87	6.49	9,250	4.62	7.06	4	2.62	.75	15
RLS502	50	2.38	22.8	3.5	9.62	10,400	4.81	7.19	4.87	2.75	.93	24
RLS1002	100	2.25	44.2	5	19.63	10,200	5.56	7.81	6.5	3.62	1.25	50



RFS20 Shown

Capacity ▶ 5 - 150 tons

Stroke ▶ .44 - .62 in.

Maximum Pressure ▶ 10,000 psi

- ▶ Plated piston to resist scoring & corrosion.
- ▶ Low profile, high tonnage design.
- ▶ Rod wiper protects inner cylinder from dirt.



HAND PUMPS - pages 31 - 41

Simplex carries the widest variety of Hand Pumps for specific applications.

Model	Base Mounting Hole Dimensions (in)
R50	.22 through x .36 C' Bore (.25 Deep)
RFS10	.28 through x .42 C' Bore (.31 Deep)
RFS20	.39 through x .62 C' Bore (.39 Deep)

Simplex RFS Series cylinders provide the ideal fit and force required for most bridge lifting and pier cap maintenance jobs. ▼

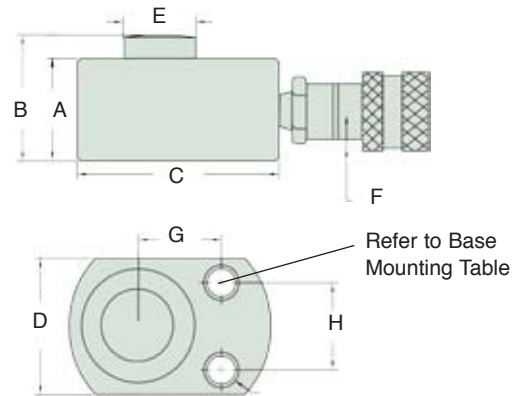

Model	Cap. (tons)	Stroke (in)	Oil Cap. Req'd (cu.in.)	Ram Bore Dia. (in)	Effective Area (sq.in.)	Pressure @ Cap. (psi)	A	B	C	D	E	F	G	H	Wgt. (lbs)
							Minimum Height (in)	Extended Height (in)	Body Length (in)	Body Width (in)	Piston O.D. (in)	Base to Port C/L (in)	Width (in)	Width (in)	
R50	5	.62	.6	1.13	.99	10,000	1.62	2.25	2.56	1.62	1	.75	1	1.13	2.5
RFS10	10	.44	1	1.68	2.24	8,940	1.68	2.13	3.25	2.19	.75	.75	1.34	1.41	3.3
RFS20	20	.44	1.9	2.38	4.43	9,030	2.03	2.47	4	3	1.13	.75	1.56	1.93	6
RFS30	30	.5	3.2	2.87	6.49	9,250	2.31	2.81	4.5	3.75	1.38	.75	---	---	8.5
RFS50	50	.62	6	3.5	9.62	10,400	2.62	3.25	5.5	4.5	1.75	.75	---	---	14.3
RFS75	75	.62	10	4.5	15.90	9,440	3.13	3.75	6.5	5.5	2.13	.75	---	---	24.5
RFS100	100	.62	12.3	5	19.63	10,200	3.38	4	7	6	2.5	.75	---	---	31
RFS150	150	.56	17.2	6.25	30.66	9,785	3.93	4.5	8.5	7.5	3	.93	---	---	50.5

STEEL CYLINDERS

RP Series - Single Acting Pull Cylinder

SIMPLEX



RP55A Shown

Capacity Range▶ 2 - 5 tons
 Stroke Range▶ 5 - 5.5 in.
 Maximum Pressure▶ 10,000 psi

- ▶ Designed for pulling & tensioning applications.
- ▶ High strength, all steel construction.
- ▶ Chrome plated piston rod resists corrosion.
- ▶ Spring loaded piston rod automatically extends when pressure is released.
- ▶ Rod wiper protects inner cylinder from dirt.

Cylinders



THINK SAFETY

Please refer to pages 4&5 for a complete list of safety tips and recommendations.



POWER PUMPS - pages 43 - 65

Simplex offers a wide variety of lightweight power pumps to fit any application.

Pull Cylinder Dimensions

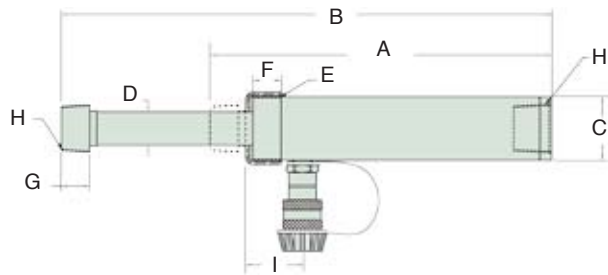

Clevis Dimensions

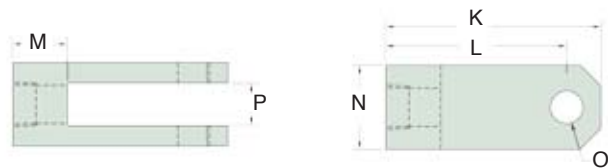

The RP55A pull cylinder and a G5 Air Pump was needed to position structural I-Beams for welding. ▼



Optional Accessories

Model	K (in)	L (in)	M (in)	N (in)	O (in)	P (in)
RPC25	5.13	4.31	1.31	2	.75	1
RPC55	6	5	1.5	2.5	.87	1.5

Both models include adapter and clevis.

Model	Capacity (tons)	Stroke (in)	Oil Capacity Required (cu. in.)	Pressure @ Capacity (psi)	A	B	C	D	E	F	G	H	I	Wgt. (lbs)
					Minimum Height (in)	Extended Height (in)	Body O.D. (in)	Piston O.D. (in)	Collar Thread (in)	Collar Thread Length (in)	Piston Adapter (in)	NPT Thread (in)	Cylinder To Port (in)	
RP25A	2	5	2.8	9,090	10.44	15.44	1.87	.75	1.5 -16	1	1.13	.75 -14	1.77	4
RP55A	5	5.5	6.2	8,850	11.88	17.38	2.25	1.19	2.25 -14	1.06	1.25	1.25-11.5	1.68	10



RDP506 Shown

Capacity Range▶ 10 - 100 tons
 Stroke Range▶ 6 in.
 Maximum Pressure▶ 10,000 psi

- ▶ Hard chrome plated steel piston rods resist corrosion.
- ▶ Ideal for joining steel plates for welding.
- ▶ Useful for the fabrication industry as well as cable tensioning.
- ▶ Double acting cylinder provides quick & full retraction.



COUPLERS - pages 74 - 75

High flow quick disconnect couplers provide a quick change to a variety of pumps.



IN-LINE VALVES - page 72

Maximize control and safety with our in-line valves.



HOSES - pages 78 - 79

Heavy duty and thermo plastic hydraulic hoses to meet your requirements and safety factor.

The Simplex RDP506 is used by this manufacturer of heavy steel cables.▼

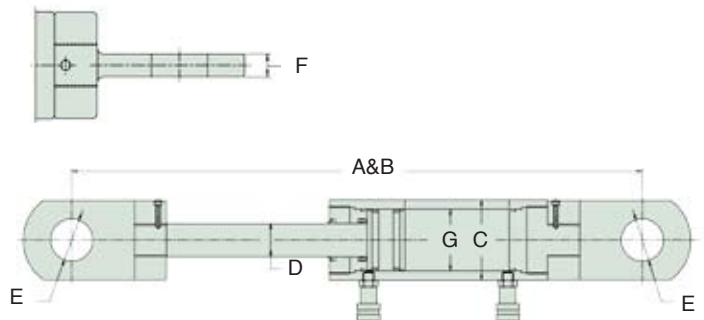

Model	Capacity (tons)	Stroke (in)	Oil Capacity Required (cu.in.)	Effect Area (sq.in.)	Pressure @ Capacity (psi)	A	B	C	D	E	F	G	Wgt. (lbs)
						Closed Dimensions (in)	Open Dimensions (in)	Body O.D. (in)	Piston O.D. (in)	Clevis Hole Diameter (in)	Clevis Width (in)	Bore Diameter (in)	
RDP106	10	6	11.5	2.4	8333	21.1	27.1	3.34	1.57	1.18	.78	2.36	30.8
RDP306	30	6	16.56	6.6	9091	26.3	32.3	4.53	1.89	2.36	.98	3.46	63.8
RDP506	50	6	25.9	11.7	8547	25.2	31.2	6.10	2.36	2.75	1.77	4.53	99
RDP1006	100	6	30.38	22.2	9010	29.1	35.1	7.80	2.56	3.15	1.97	5.91	193.6

STEEL CYLINDERS

RC Series - Single Acting Center Hole

SIMPLEX



RC603A Shown

Capacity Range► 12 - 100 tons

Stroke Range► .31 - 6.13 in.

Maximum Pressure► 10,000 psi

- Induction hardened piston rod for added strength eliminating the need for a loadcap.
- Collar threads for easy fixturing.
- Design allows for both push & pull forces.
- Large center hole for greater flexibility.



POWER PUMPS - pages 43 - 65

Simplex offers a wide variety of lightweight power pumps to fit any application.



CENTER HOLE

Corrosion resistant technology on the piston rod and retaining nut extends cylinder life.

Cylinders

Base Mounting Hole Dimensions

Model	Bolt Circle (in)	Thread (in)	Thread Depth (in)
RC120A	2.00	5/16 - 18 UNC	.25
RC121A	NO TAPPED HOLES		
RC123A	2.00	5/16 - 18 UNC	.50
20 Ton	3.25	3/8 - 16 UNC	.37
30 Ton	3.63	3/8 - 16 UNC	.62
60 Ton	5.13	1/2 - 13 UNC	.55
RC1003A	7.00	5/8 - 11 UNC	.75

• Refer to Base Mounting Table

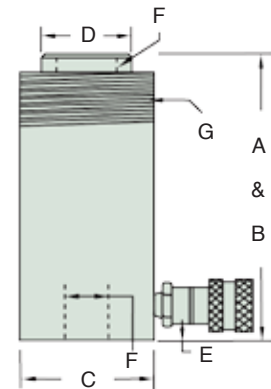
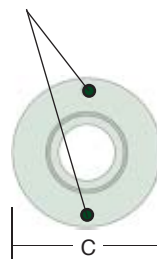

Model	Cap. (tons)	Stroke (in)	Oil Capacity Required (cu. in.)	Effect Area (sq. in.)	Pres. @ Cap. (psi)	A	B	C	D	E	F	G		Wgt. (lbs)
						Minimum Height (in)	Extended Height (in)	Body O.D. (in)	Piston O.D. (in)	Base to Port C/L (in)	Center Hole Diameter (in)	Collar Threads (in)	Collar Thread Length (in)	
RC120A	12	0.31	.86	2.76	8,695	2.2	2.5	2.75	1.38	0.38	.77	2 3/4-16	1.19	3.5
RC121A	12	1.63	4.5	2.76	8,695	4.75	6.38	2.75	1.38	0.98	.77	2 3/4-16	1.19	6.5
RC123A	12	3	8.3	2.76	8,695	7.25	10.25	2.75	1.38	0.98	.77	2 3/4-16	1.19	10
RC202A	20	2	9.46	4.73	8,456	6.42	8.42	3.88	2.12	0.75	1.06	3 7/8-12	1.50	17
RC206A	20	6.10	28.67	4.73	8,456	12.09	18.09	3.88	2.12	0.75	1.06	3 7/8-12	1.50	31
RC302A	30	2.5	18.05	7.22	8,310	7.03	9.53	4.5	2.5	0.85	1.31	4 1/2-12	1.66	24
RC306A	30	6.13	44.23	7.22	8,310	13	19.13	4.5	2.5	1.00	1.31	4 1/2-12	1.66	48
RC603A	60	3	38.29	12.73	9,426	9.75	13.25	6.26	3.62	1.25	2.12	6 1/4-12	1.91	62
RC606A	60	6	76.41	12.73	9,426	12.75	18.75	6.26	3.26	1.25	2.12	6 1/4-12	1.91	78
RC1003A	100	3	62	20.60	9,694	10	13	8.38	5	1.50	3.11	8 3/8-12	2.38	132



RCD307A Shown

Capacity Range ▶ 30 - 500 tons

Stroke Range ▶ 3 - 10.13 in.

Maximum Pressure ▶ 10,000 psi

- ▶ Design allows for both push & pull forces.
- ▶ Induction hardened piston rod for added strength eliminating the need for a loadcap.
- ▶ Performance Nitride/QPQ corrosion resistant technology on the piston rod and retaining nut for extended cylinder life.



RELIEF VALVE

Relief valve prevents damage in case of over pressurization.



HOSES - pages 78 - 79

Heavy duty and thermo plastic hydraulic hoses to meet your requirements and safety factor.

Base Mounting Hole Dimensions

Model	Bolt Circle (in)	Thread (in)	Thread Depth (in)
30 Ton	3.63	3/8 - 16 UNC	.62
60 Ton	5.12	1/2 - 13 UNC	.55
100 Ton	7.00	5/8 - 11 UNC	.75

• Refer to Base Mounting Table

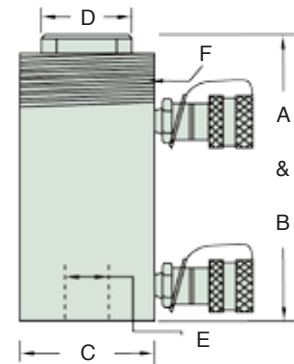
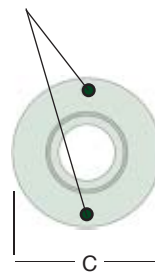

Model	Push Capacity (tons)	Stroke (in)	Oil Capacity Required (cu.in.)	Push Effect Area (sq.in.)	Pres. @ Cap. (psi)	A	B	C	D	E	F		Wgt. (lbs)
						Minimum Height (in)	Extended Height (in)	Body O.D. (in)	Piston O.D. (in)	Center Hole Dia. (in)	Collar Threads (in)	Collar Threads Length (in)	
RCD307A	36	7	50.55	7.22	8,310	13	20	4.5	2.5	1.31	4 1/2-12	1.66	48
RCD6010A	64	10.12	128.94	12.73	9,426	17.25	27.37	6.26	3.62	2.13	6 1/4-12	1.91	101
RCD1003A	103	3	61.88	20.63	9,694	10	13	8.38	5.0	3.13	8 3/8-12	2.38	135
RCD1006A	103	6	123.76	20.63	9,694	13.50	19.50	8.38	5.0	3.13	8 3/8-12	2.38	175
RCD10010A	103	10.13	208.84	20.63	9,694	18.12	28.25	8.38	5.0	3.13	8 3/8-12	2.38	235
RCD1505	150	5	78	31.6	9,491	13.13	18.13	10	6	3.13	---	---	240
RCD2006C	246	6	172	49.3	10,000	16.25	22.25	12	8	4.13	---	---	385
RCD3006C	434	6	296	91.5	10,000	18.75	24.75	15	9.5	4.25	---	---	720
RCD5006C	646	6	463	129.3	10,000	21.5	27.5	17.75	12	5.25	---	---	1230

STEEL CYLINDERS

RLR Series - Load Return

SIMPLEX



RLR1006 Shown

Capacity Range▶ 30 - 1000 tons

Stroke Range▶ 6 - 12 in.

Maximum Pressure▶ 10,000 psi

- ▶ Large bearings resist side load.
- ▶ Plated piston to resist scoring & corrosion.
- ▶ Stop ring for piston blow-out protection.
- ▶ Custom strokes and capacities up to 1,500 tons available, contact factory.
- ▶ Swivel Eye Bolts are used 100 tons and up.

THINK SAFETY



Please refer to pages 4&5 for a complete list of safety tips and recommendations.

POWER PUMPS - pages 43 - 65



Simplex offers a wide variety of lightweight power pumps to fit any application.

SWIVEL LOAD CAP



5° swivel load caps on 30-100 ton models help stabilize the load.

DESIGN CONSTRUCTION 150+ TONS



Piston Flange

A thick bronze inlay on the piston flange virtually eliminates scoring of cylinder bore while offering the best protection against accidental side loading. (150 Tons and up)

A ten cylinder system, using RLR40012 cylinders, is used to lift the bed of this dragline so that maintenance can be performed on the rollers.▼



• Note: 100 Ton Models Have Eyebolts For Positioning

30 - 100 Tons

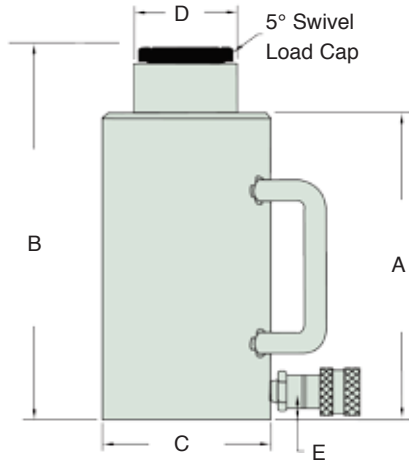

150 - 1000 Tons

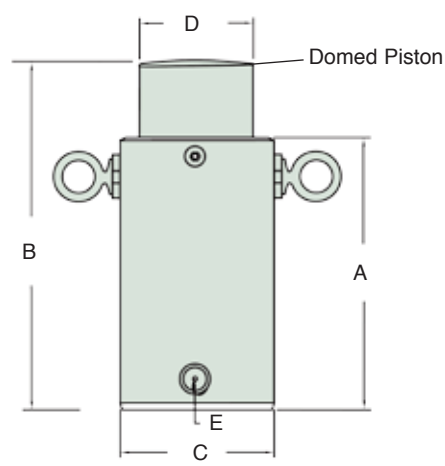

Model	Cap. (tons)	Stroke (in)	Oil Capacity Required (cu.in.)	Ram Bore Diameter (in)	Effective Area (sq in)	Pressure @ Capacity (psi)	A	B	C	D	E	Wgt. (lbs)
							Minimum Height (in)	Extended Height (in)	Body O.D. (in)	Piston O.D. (in)	Base to Port C/L (in)	
RLR306	30	6	38.9	2.87	6.49	9,240	9.38	15.38	4	2	.75	32
RLR502	50	2	22.1	3.75	11.05	9,054	5.44	7.44	5	3	.78	30
RLR506	50	6	66.3	3.75	11.05	9,054	9.44	15.44	5	3	.78	55
RLR5010	50	10	133	3.75	11.05	9,054	13.44	23.44	5	3	.78	92
RLR1006	100	6	118	5	19.63	10,200	10.56	16.56	6.38	3.38	1.25	90
RLR10010	100	10	196	5	19.63	10,200	14.56	24.56	6.38	3.38	1.25	126
RLR1502	150	2	66.4	6.25	30.68	9,778	7	9	9	5.56	1.25	117
RLR1506	150	6	199	6.25	30.68	9,778	11	17	9	5.56	1.93	189
RLR15012	150	12	398	6.25	30.68	9,778	17	29	9	5.56	1.93	297
RLR2002	200	2	88.4	7.25	41.28	9,054	8	10	10	6.56	2.06	184
RLR2006	200	6	265	7.25	41.28	9,054	12	18	10	6.56	2.06	282
RLR20012	200	12	530	7.25	41.28	9,054	18	30	10	6.56	2.06	429
RLR3002	300	2	120	8.75	60.13	9,978	11.5	13.5	12	7.81	2.44	277
RLR3006	300	6	361	8.75	60.13	9,978	13.75	19.75	12	7.81	2.44	405
RLR30012	300	12	722	8.75	60.13	9,978	19.75	31.75	12	7.81	2.44	597
RLR4002	400	2	174	10.5	86.59	9,238	11.5	13.5	14	6.56	3	455
RLR4006	400	6	520	10.5	86.59	9,238	15.5	21.5	14	6.56	3	612
RLR40012	400	12	1040	10.5	86.59	9,238	21.5	33.5	14	6.56	3	842
RLR5002	500	2	208	11.5	103.87	9,628	12.62	14.62	16	10.31	3.19	627
RLR5006	500	6	623	11.5	103.87	9,628	16.62	22.62	16	10.31	3.19	855
RLR50012	500	12	1246	11.5	103.87	9,628	22.62	34.62	16	10.31	3.19	1197
RLR6002	600	2	246	12.5	122.71	9,778	13.5	15.5	17.5	11.31	3.5	655
RLR6006	600	6	738	12.5	122.71	9,778	17.5	23.5	17.5	11.31	3.5	902
RLR60012	600	12	1476	12.5	122.71	9,778	23.5	35.5	17.5	11.31	3.5	1273
RLR8002	800	2	330	14.5	165.13	9,690	14.44	16.44	18	13.31	4.13	997
RLR8006	800	6	991	14.5	165.13	9,690	18.44	24.44	18	13.31	4.13	1256
RLR80012	800	12	1982	14.5	165.13	9,690	24.44	36.44	18	13.31	4.13	1644
RLR10002	1000	2	402	16	201.06	9,950	16.13	18.13	21	14.93	4.25	1523
RLR10006	1000	6	1206	16	201.06	9,950	20.13	26.13	21	14.93	4.25	1883
RLR100012	1000	12	2412	16	201.06	9,950	26.13	38.13	21	14.93	4.25	2423

STEEL CYLINDERS

RLN Series - Locknut Load Return

SIMPLEX



RLN1006 Shown

Capacity Range ▶ 30 - 1000 tons

Stroke Range ▶ 2 - 12 in.

Maximum Pressure ▶ 10,000 psi

- ▶ Lock nuts offer extended load holding.
- ▶ Stop ring for piston blow-out protection.
- ▶ 5° swivel load caps on 30-100 ton models for side load protection.
- ▶ Custom strokes and capacities up to 1,500 tons available, contact factory.

Cylinders



HOSES - pages 78 - 79

Heavy duty and thermo plastic hydraulic hoses to meet your requirements and safety factor.



POWER PUMPS - pages 43 - 65

Simplex offers a wide variety of lightweight power pumps to fit any application.



SWIVEL EYE BOLTS

Swivel Eye Bolts are used on 100 tons and up.

DESIGN CONSTRUCTION 200+ TONS



Acme Screw

Class 2 ACME Thread offers high strength & ease to move lock-nut into position for load holding.

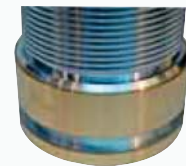

Piston Flange

A thick bronze inlay on the piston flange virtually eliminates scoring of cylinder bore while offering the best protection against accidental side loading. (200 Tons and up)

Simplex RLN Series cylinders are used to lift and hold this large platform for maintenance at this shipyard. ▼



• Note: 100 Ton Models Have Eyebolts For Positioning

30 - 100 Tons

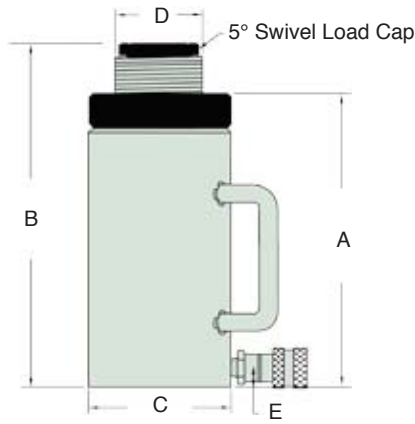

150 - 1000 Tons

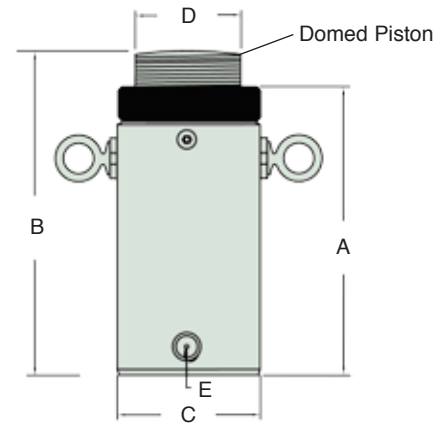

Model	Cap. (tons)	Stroke (in)	Oil Capacity Required (cu.in.)	Ram Bore Diameter (in)	Effect Area (sq.in.)	Pressure @ Capacity (psi)	A	B	C	D	E	Wgt. (lbs)
							Minimum Height (in)	Extended Height (in)	Body O.D. (in)	Piston O.D. (in)	Base to Port C/L (in)	
RLN302	30	2	13	2.87	6.49	9,240	6.38	8.38	4	2.44	.75	21
RLN306	30	6	38.9	2.87	6.49	9,240	10.38	16.38	4	2.44	.75	35
RLN502	50	2	22.1	3.75	11.05	9,054	6.75	8.75	5	3.19	.78	38
RLN506	50	6	66.2	3.75	11.05	9,054	10.75	16.75	5	3.19	.78	63
RLN5010	50	10	133	3.75	11.05	9,054	14.75	24.75	5	3.19	.78	100
RLN1002	100	2	40	5	19.63	10,200	8	10	6.38	4.31	1.25	87
RLN1006	100	6	118	5	19.63	10,200	12	18	6.38	4.31	1.25	132
RLN10010	100	10	196	5	19.63	10,200	16	26	6.38	4.31	1.25	202
RLN1502	150	2	66.4	6.25	30.68	9,780	8	10	8.5	5.56	1.93	149
RLN1506	150	6	199	6.25	30.68	9,780	12.25	18	8.5	5.56	1.93	221
RLN15012	150	12	398	6.25	30.68	9,780	18	30	8.5	5.56	1.93	311
RLN2002	200	2	88.4	7.25	41.28	9,054	9.5	11.5	10	6.56	2.06	233
RLN2006	200	6	265	7.25	41.28	9,054	13.5	19.5	10	6.56	2.06	332
RLN20012	200	12	530	7.25	41.28	9,054	19.5	31.5	10	6.56	2.06	479
RLN3002	300	2	120	8.75	60.13	9,978	11.5	13.5	12	7.81	2.44	357
RLN3006	300	6	361	8.75	60.13	9,978	15.5	21.5	12	7.81	2.44	485
RLN30012	300	12	722	8.75	60.13	9,978	21.5	33.5	12	7.81	2.44	677
RLN4002	400	2	174	10.5	86.59	9,238	13.81	15.81	14	9.31	3	520
RLN4006	400	6	520	10.5	86.59	9,238	17.81	23.81	14	9.31	3	675
RLN40012	400	12	1040	10.5	86.59	9,238	23.81	25.81	14	9.31	3	905
RLN5002	500	2	208	11.5	103.87	9,628	14.75	16.75	16	10.31	3.19	927
RLN5006	500	6	623	11.5	103.87	9,628	18.75	24.75	16	10.31	3.19	1041
RLN50012	500	12	1246	11.5	103.87	9,628	24.75	36.75	16	10.31	3.19	1383
RLN6002	600	2	246	12.5	122.79	9,778	15.62	17.62	17.5	11.31	3.5	985
RLN6006	600	6	738	12.5	122.79	9,778	19.62	25.62	17.5	11.31	3.5	1232
RLN60012	600	12	1476	12.5	122.79	9,778	27.62	39.62	17.5	11.31	3.5	1603
RLN8002	800	2	330	14.5	165.13	9,690	16.93	18.93	18	13.31	4.13	1148
RLN8006	800	6	991	14.5	165.13	9,690	21.93	27.93	18	13.31	4.13	1407
RLN80012	800	12	1982	14.5	165.13	9,690	27.93	39.93	18	13.31	4.13	1795
RLN10002	1000	2	402	16	201.06	9,950	19.62	21.62	21	14.81	4.25	1818
RLN10006	1000	6	1206	16	201.06	9,950	23.62	29.62	21	14.81	4.25	2178
RLN100012	1000	12	2412	16	201.06	9,950	29.62	41.62	21	14.81	4.25	2718



RDA10006 Shown -
with optional o/c valve (sold separately)

Capacity Range▶ 10 - 1000 tons

Stroke Range▶ 2 - 24 in.

Maximum Pressure▶ 10,000 psi

- ▶ Collar threads designed for full load (10-200 tons).
- ▶ Removable load cap for flexibility and safety.
- ▶ Stop ring for piston blow-out protection.
- ▶ Plated piston to resist scoring & corrosion.
- ▶ Large bearings resist side load.
- ▶ Rod wiper protects inner cylinder from dirt.
- ▶ Custom strokes and capacities up to 1,500 tons available, contact factory.

GAUGES - page 77



Improve your system visibility and safety by adding an inline hydraulic gauge to your circuit.

POWER PUMPS - pages 43 - 65



Simplex offers a wide variety of lightweight power pumps to fit any application.

MANIFOLDS - page 73



The ideal solution in obtaining precise control when operating multiple cylinders.

DESIGN CONSTRUCTION 200+ TONS



Bronze Inlay

Thick bronze inlay on the inner diameter of the retaining nut protects the piston rod.



Piston Flange

A thick bronze inlay on the piston flange virtually eliminates scoring of cylinder bore while offering the best protection against accidental side loading. (200 Tons and up)

Maintenance crews relied on Simplex RDA15018 cylinders to help lift, transport and launch a U.S. Navy research ship from dry dock to the ship's launch site. ▼



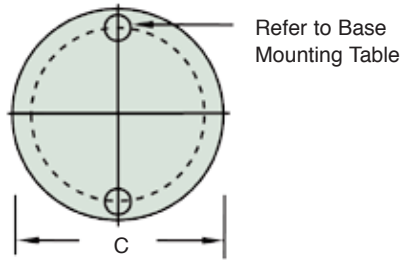

Base Mounting Hole Dimensions

Model	Thread		Bolt Circle Diameter (in)
	Size (in)	Depth (in)	
55 Ton	.62 -11	.75	3.75
100 Ton	.62 -11	1	4.25
150 Ton	1-8	1.38	5
200 Ton	1-8	1.13	5

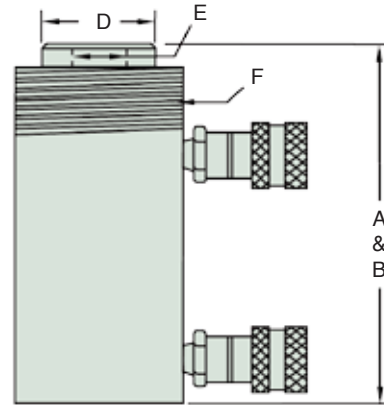

Model	Push Cap. (tons)	Pull Cap. (tons)	Stroke (in)	Oil Cap. Req'd. (cu.in.)	Ram Bore Dia. (in)	Push Effect Area (sq. in)	Pull Effect. Area (sq.in)	Pres. @ Cap. (psi)	A	B	C	D	E	F		Wgt. (lbs)	
									Min. Ht. (in)	Ext. Ht. (in)	Body O.D. (in)	Piston O.D. (in)	Piston I.D. Thrds. (in)	Piston Thrd. Depth (in)	Collar Thrds. (in)		Collar Thrd. Lgth. (in)
RDA1010	10	4	10	22	1.68	2.23	.80	8,960	16.13	26.13	2.87	1.38	1-8	1	2.25-14	1.06	28
RDA308	30	12.5	8.13	34	2.87	6.51	3	9,250	15.75	23.75	4	2.13	1.5-16	1	3.31-12	1.93	40
RDA3014	30	12.5	14.5	91	2.87	6.51	3	9,250	21.62	36.13	4	2.13	1.5-16	1	3.31-12	1.93	64
RDA556	55	17	6.13	46	3.75	11.05	3.4	9,955	13.13	19.25	5	3.13	1-12	1.5	5-12	1.75	68
RDA5512	55	17	12	92	3.75	11.05	3.4	9,955	19.13	31.13	5	3.13	1-12	1.5	5-12	1.75	114
RDA5524	55	17	24	184	3.75	11.05	3.4	9,955	31.62	55.62	5	3.13	1-12	1.5	5-12	1.75	201
RDA1006	100	45	6.06	77	5.25	21.65	9.08	9,239	13.87	19.93	7	4	3.25-12	2.5	7-12	2.5	140
RDA10012	100	45	12	151	5.25	21.65	9.08	9,239	19.87	31.87	7	4	3.25-12	2.5	7-12	2.5	187
RDA1506	150	67	6.06	120	6.5	33.18	13.55	9,041	15.44	21.5	8.5	5	3.5-12	2.75	8.5-12	2.19	218
RDA15012	150	67	12	236	6.5	33.18	13.55	9,041	21.5	33.5	8.5	5	3.5-12	2.75	8.5-12	2.19	295
RDA2002	200	72	2	66	7.5	44.18	15.91	9,054	11.44	13.44	10	6	2.5-12	2.5	9.75-12	1.87	232
RDA2006	200	72	6	170	7.5	44.18	15.91	9,054	15.44	21.44	10	6	2.5-12	2.5	9.75-12	1.87	315
RDA20013	200	72	13	368	7.5	44.18	15.91	9,054	22.44	35.44	10	6	2.5-12	2.5	9.75-12	1.87	440
RDA3002	355	----	2	101	9.5	70.9	20.62	10,000	13.25	15.25	12	8	----	----	----	----	277
RDA3006	355	----	6	302	9.5	70.9	20.62	10,000	17.25	23.25	12	8	----	----	----	----	441
RDA30012	355	----	12	605	9.5	70.9	20.62	10,000	23.25	35.25	12	8	----	----	----	----	688
RDA4002	565	----	2	127	12	113	49.48	10,000	12.38	14.38	14.5	9	----	----	----	----	530
RDA4006	565	----	6	382	12	113	49.48	10,000	16.62	22.62	14.5	9	----	----	----	----	670
RDA40012	565	----	12	762	12	113	49.48	10,000	22.87	34.87	14.5	9	----	----	----	----	880
RDA5002	664	----	2	156	13	132	54.19	10,000	16.5	18.5	16	10	----	----	----	----	722
RDA5006	664	----	6	471	13	132	54.19	10,000	20.5	26.5	16	10	----	----	----	----	953
RDA50012	664	----	12	942	13	132	54.19	10,000	26.5	38.5	16	10	----	----	----	----	1300
RDA6002	600	----	2	158	12.5	122.71	44.17	10,000	15	17	17	10	----	----	----	----	917
RDA6006	600	----	6	472	12.5	122.71	44.17	10,000	19	25	17	10	----	----	----	----	1188
RDA60012	600	----	12	944	12.5	122.71	44.17	10,000	25	37	17	10	----	----	----	----	1595
RDA8002	800	----	2	226	14.5	165.13	52.03	9,690	16	18	18.5	10	----	----	----	----	1166
RDA8006	800	----	6	991	14.5	165.13	52.03	9,690	21.5	27.5	18.5	10	----	----	----	----	1461
RDA80012	800	----	12	1,360	14.5	165.13	52.03	9,690	26	38	18.5	10	----	----	----	----	1776
RDA10002	1000	----	2	354	17	227	50.27	8,810	16	18	21	15	----	----	----	----	1558
RDA10006	1000	----	6	1,071	17	227	50.27	8,810	20	26	21	15	----	----	----	----	2058
RDA100012	1000	----	12	2,142	17	227	50.27	8,810	27	39	21	15	----	----	----	----	2808

STEEL CYLINDERS

CLP Series - Pancake Locknut

SIMPLEX



Capacity Range▶ 60 - 500 tons
 Stroke Range▶ 1.77 - 1.97 in.
 Maximum Pressure▶ 10,000 psi

- ▶ Extra low profile to fit into tight spaces.
- ▶ 5° swivel load caps on all models.
- ▶ Locknut design provides positive mechanical load hold.
- ▶ Single acting load return with overload protection port.
- ▶ Carrying handles and eye bolts on all models.

CLP-1002 Shown



POWER PUMPS - pages 43 - 65
 Simplex offers a wide variety of lightweight power pumps to fit any application.



HOSES - pages 78 - 79
 Heavy duty and thermo plastic hydraulic hoses to meet your requirements and safety factor.

Cylinders

Simplex CLP Series cylinders are designed specifically for lifting and load holding where space is at a minimum. ▼

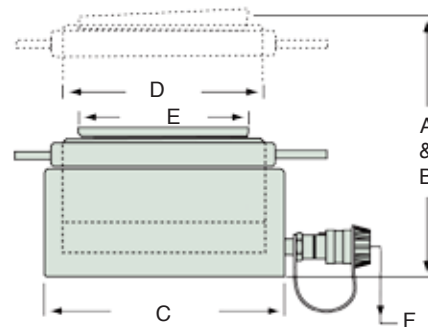

Model	Capacity Tons	Stroke (in)	Oil Capacity Required (cu.in.)	Ram Bore Diameter (in)	Effective Area (sq.in.)	Pressure @ Capacity (psi)	A	B	C	D	E	F	Wgt. (lbs)
							Minimum Height (in)	Extended Height (in)	Body O.D. (in)	Piston O.D. Thread (mm)	Saddle Diameter (in)	Base to Port (in)	
CLP-602	60	1.97	26.4	4.1	13.4	8955	4.9	6.7	5.5	105 X 6	3.8	.8	33
CLP-1002	100	1.97	43.7	5.3	22.2	9009	5.4	7.2	6.9	135 X 6	5	.8	57
CLP-1502	150	1.77	58.7	6.5	33.1	9063	5.8	7.8	8.7	165 X 6	5.9	1.1	97
CLP-2002	200	1.77	77.8	7.5	49.9	8016	6.1	8.1	9.6	190 X 6	7.1	1.2	125
CLP-2502	250	1.77	99.7	8.5	56.3	8881	6.3	8.3	10.8	215 X 6	7.9	1.3	165
CLP-4002	400	1.77	157.1	10.6	88.7	9019	7	9	13.8	270 X 8	9.9	1.5	297
CLP-5002	500	1.77	194	11.8	109.6	9124	7.6	9.6	15.8	300 X 8	11.2	1.9	418

Cylinder Bases

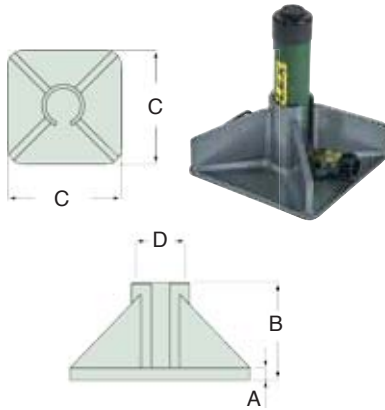

Model	A (in)	B (in)	C (in)	D (in)
BA10	.39	4.72	9.06	2.28
BA25	.63	4.96	11.02	3.39

BA10 for R102 through R1014
BA25 for R252 through R2514

Cylinder Load Caps



Model	Type of Cylinder
18347	Used on R5 Series
18348	Used on R10 & R15 Series
85525	Used on R25 Series
85525	Used on R30 Series
85546	Used on R55 Series
85546	Used on R75 Series
85546	Used on R100 Series
18348	Used on RDA10 Series
85525	Used on RDA30 Series
88390	Used on RDA55 Series
18323	Used on RDA100 Series
18326	Used on RDA150 Series
87721	Used on RDA200 Series

Tilt Saddles



Model	A (in)	B (in)	C (in)
ATS10	1.38	.59	.88
ATS25	1.97	.83	1.4
ATS100	2.82	1.55	---

ATS10 for R102 through R1014
ATS25 for R251 through R2514

ATS100 for R-Series 55, 75 and 100 ton cylinders

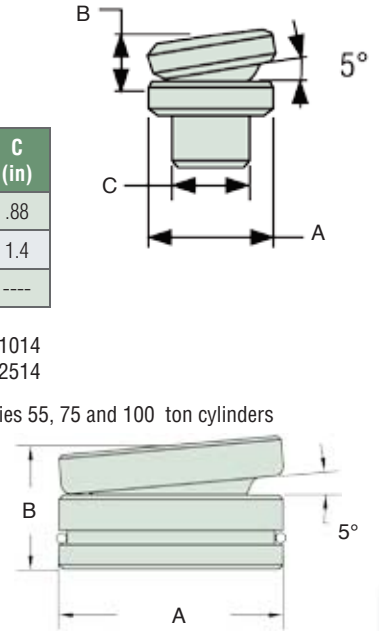

Mounting Blocks For R5 Series Cylinders

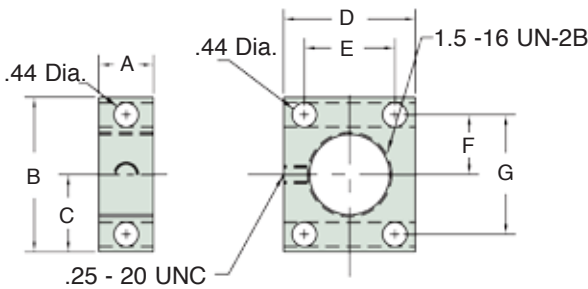

Model	A (in)	B (in)	C (in)	D (in)	E (in)	F (in)	G (in)
BR5	.99	2.75	1.38	2.36	1.62	1.06	2.12

Mounting Blocks



Mounting Blocks For R10, R15 & R25 Series Cylinders

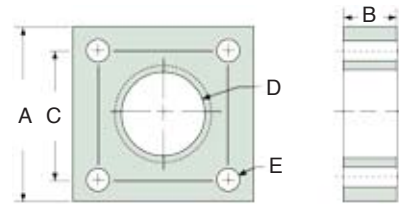

Model	A (in)	B (in)	C (in)	D (in)	E (in)
BR10	3.5	1	2.63	2.25-14 UN-2B	.34
BR15	3.5	1	2.63	2.75-16 UN-2B	.34
BR25	5	2	3.66	3.93-12 UN-2B	.66

For R-Series 5, 10, 15 & 25 ton cylinders

Model	A (in)	B (in)	C (in)	D (in)	E (in)	F (in)
BCR5	1.12	1.74	.56	.63	.62	.76
BCR10	1.69	2.44	1	.88	1	1.12
BCR15	1.69	2.44	1	.88	1	1.12
BCR25	2.25	2.82	1.5	1.26	1.25	1.37

Piston Clevis

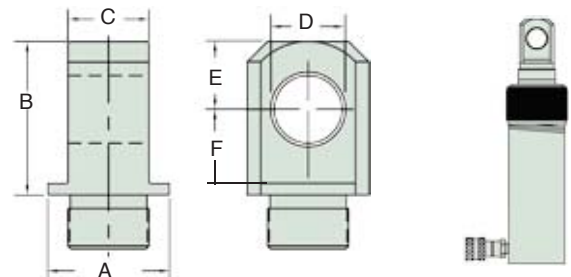

For R-Series 10, 15 & 25 ton cylinders

Model	A (in)	B (in)	C (in)	D (in)	E (in)	F (in)	G (under cut)
BC10	2.5	2.88	1	.88	1	1.38	.25
BC15	3	2.88	1	.88	1	1.38	.25
BC25	3.75	3.38	1.5	1.26	1.25	1.53	.25

Base Clevis

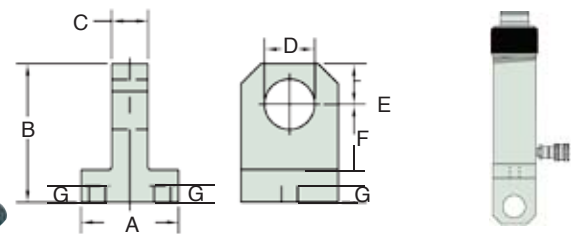

ALUMINUM CYLINDERS

RAS Series - Spring Return

SIMPLEX



RAS306B Shown

Capacity Range▶ 30 - 150 tons

Stroke Range▶ 2 - 10 in.

Maximum Pressure▶ 10,000 psi

- ▶ Half the weight of steel cylinders.
- ▶ Heavy duty spring for fast & full retraction.
- ▶ Large bearing surfaces for side load protection.
- ▶ Technical coating reduces wear & corrosion.
- ▶ Stop rings for piston blow out protection.
- ▶ Rod wiper protects inner cylinder from dirt.



POWER PUMPS - pages 43 - 65

Simplex offers a wide variety of lightweight power pumps to fit any application.

The RAS302B spring return cylinder along with a P32 aluminum hand pump is easy to carry and position in tight places. ▼

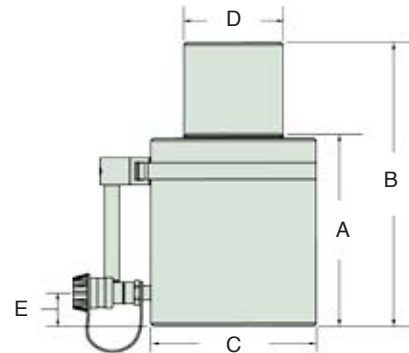

Model	Capacity (tons)	Stroke (in)	Oil Capacity Required (cu. in.)	Effect Area (sq. in)	Pressure @ Capacity (psi)	A	B	C	D	E	Wgt. (lbs)
						Minimum Height (in)	Extended Height (in)	Body O.D. (in)	Piston O.D. (in)	Base to Port C/L (in)	
RAS302B	30	2	13	6.5	9231	6.5	8.5	4.5	2.5	1.5	14
RAS306B	30	6	39	6.5	9231	10.5	16.5	4.5	2.5	1.5	18
RAS502B	50	2	22.1	11	9091	6.5	8.5	5.5	3.13	1.5	13
RAS504B	50	4	44.2	11	9091	8.5	12.5	5.5	3.13	1.5	17
RAS506B	50	6	66.2	11	9091	10.5	16.5	5.5	3.13	1.5	28
RAS5010B	50	10	110.4	11	9091	14.5	24.5	5.5	3.13	1.5	36
RAS1002B	100	2	41.2	20.7	9662	6.5	8.5	8	4.25	1.5	40
RAS1004B	100	4	82.4	20.7	9662	8.5	12.5	8	4.25	1.5	45
RAS1006B	100	6	123.7	20.7	9662	10.5	16.5	8	4.25	1.5	50
RAS10010B	100	10	206	20.7	9662	14.5	24.5	8	4.25	1.5	68
RAS1502B	150	2	61.4	30.7	9772	6.5	8.5	10	4.87	1.5	58
RAS1506B	150	6	184.1	30.7	9772	10.5	16.5	10	4.87	1.5	86
RAS15010B	150	10	306.8	30.7	9772	14.5	24.5	10	4.87	1.5	110

Cylinders



RAL502 Shown

Capacity Range ▶ 50 - 150 tons

Stroke Range ▶ 2 - 10 in.

Maximum Pressure ▶ 10,000 psi

- ▶ Technical coating reduces wear & corrosion.
- ▶ Carrying handles standard on all models.
- ▶ Half the weight of steel cylinders.
- ▶ Locknuts offer extended load holding.
- ▶ Stop rings for piston blow out protection.
- ▶ Heavy duty spring for fast & full retraction.



COUPLERS - pages 74 - 75

High flow quick disconnect couplers provide a quick change to a variety of pumps.



HOSES - pages 78 - 79

Heavy duty and thermo plastic hydraulic hoses to meet your requirements and safety factor.

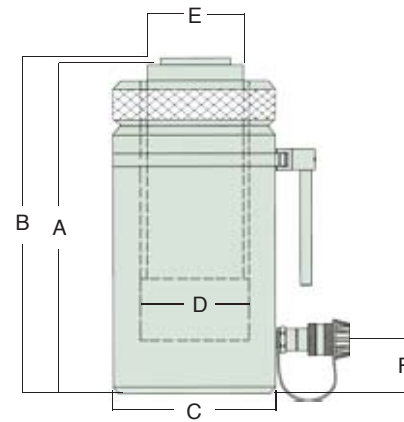

Model	Cap. (tons)	Stroke (in)	Oil Capacity Required (cu.in.)	Effect Area (sq.in.)	Pressure @ Capacity (psi)	A	B	C	D	E	F	Wgt. (lbs)
						Minimum Height (in)	Extended Height (in)	Body O.D. (in)	Cylinder Bore Diameter (in)	Piston O.D. (in)	Base to Port C/L (in)	
RAL502	50	2	21.65	11.04	9058	8.13	10.13	5.5	3.75	3.13	1.5	20
RAL504	50	4	43.3	11.04	9058	10.13	14.13	5.5	3.75	3.13	1.5	25
RAL506	50	6	64.92	11.04	9058	12.13	18.13	5.5	3.75	3.13	1.5	30
RAL5010	50	10	108.2	11.04	9058	16.13	26.13	5.5	3.75	3.13	1.5	40
RAL1002	100	2	40.51	20.68	9671	8.38	10.38	8	5.13	4.25	1.5	45
RAL1004	100	4	81	20.68	9671	10.38	14.38	8	5.13	4.25	1.5	55
RAL1006	100	6	121.5	20.68	9671	12.38	18.38	8	5.13	4.25	1.5	64
RAL10010	100	10	202.5	20.68	9671	16.38	26.38	8	5.13	4.25	1.5	82
RAL1502	150	2	60.6	30.68	9778	8.38	10.38	10	6.25	5	1.5	65
RAL1506	150	6	181.8	30.68	9778	12.38	18.38	10	6.25	5	1.5	101
RAL15010	150	10	303	30.68	9778	16.38	26.38	10	6.25	5	1.5	156

ALUMINUM CYLINDERS

RAC Series - Single Acting Center Hole

SIMPLEX



Capacity Range▶ 30 - 60 tons

Stroke Range▶ 3 - 6 in.

Maximum Pressure▶ 10,000 psi

- ▶ Half the weight of steel cylinders.
- ▶ Heavy duty spring for fast & full retraction.
- ▶ Technical coating reduces wear & corrosion.
- ▶ Stop rings for piston blow-out protection.
- ▶ Rod wiper protects inner cylinder from dirt.

RAC303 Shown



POWER PUMPS - pages 43 - 65

Simplex offers a wide variety of lightweight power pumps to fit any application.



CENTER HOLE

Chrome plated center hole for extra protection.

Cylinders

The Simplex RAC306A 30 ton single acting aluminum center hole cylinder is used to pull pins from off road equipment. ▼

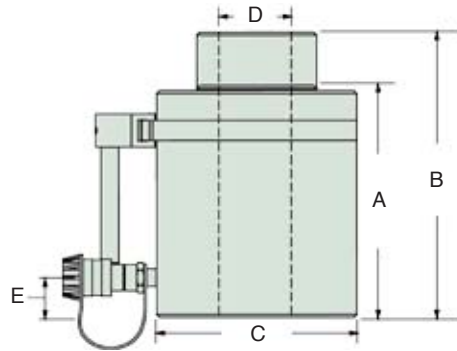

Model	Capacity (tons)	Stroke (in)	Oil Capacity Required (cu.in.)	Effect Area (sq.in.)	Pressure @ Capacity (psi)	A	B	C	D	E	Wgt. (lbs)
						Minimum Height (in)	Extended Height (in)	Body O.D. (in)	Center Hole (in)	Base to Port C/L (in)	
RAC303	30	3	22	7.21	8321	8.75	11.75	5.5	1.19	1	22
RAC306A	30	6	44	7.21	8321	11.75	17.75	5.5	1.19	1	30
RAC603	60	3	37	12.3	9756	10.13	13.13	7.5	2.13	1	42
RAC606	60	6	74	12.3	9756	13.25	19.25	7.5	2.13	1	55



Capacity Range ▶ 30 - 150 tons
 Stroke Range ▶ 2 - 10 in.
 Maximum Pressure ▶ 10,000 psi

- ▶ Technical coating reduces wear & corrosion.
- ▶ Steel piston for protection against load damage.
- ▶ Chrome plated sleeve for extra protection.
- ▶ Stop rings for piston blow-out protection.
- ▶ Rod wiper protects inner cylinder from dirt.

RACD306 Shown



RELIEF VALVE

Relief valve prevents damage in case of over pressurization.



CARRYING HANDLES

2 Carrying handles on models RACD1002 & RACD15010 for ease of mobility.

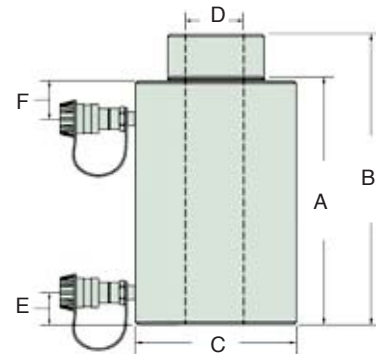

Cylinders

Model	Capacity (tons)	Stroke (in)	Oil Capacity Required (cu.in.)	Effect Area (sq.in.)	Pressure @ Capacity (psi)	A	B	C	D	E	F	Wgt. (lbs)
						Minimum Height (in)	Extended Height (in)	Body O.D. (in)	Center Hole Diameter (in)	Base to Port C/L (in)	Collar to Port C/L (in)	
RACD302	30	2	14.34	6.35	9449	7	9	5.5	1.5	1.75	1.75	20
RACD306	30	6	43.02	6.35	9449	11	17	5.5	1.5	1.75	1.75	28
RACD3010	30	10	71.7	6.35	9449	15	25	5.5	1.5	1.75	1.75	35
RACD502	50	2	21.71	10.3	9709	7	9	7.5	2.13	1.75	1.75	33
RACD504	50	4	43.44	10.3	9709	9	13	7.5	2.13	1.75	1.75	41
RACD506	50	6	65.16	10.3	9709	11	17	7.5	2.13	1.75	1.75	49
RACD5010	50	10	108.6	10.3	9709	15	25	7.5	2.13	1.75	1.75	65
RACD1002	100	2	41.52	20.28	9862	10	12	11	3.5	2.5	2.5	85
RACD1004	100	4	83.04	20.28	9862	12	16	11	3.5	2.5	2.5	105
RACD1006	100	6	124.56	20.28	9862	14	20	11	3.5	2.5	2.5	120
RACD10010	100	10	206.6	20.28	9862	18	28	11	3.5	2.5	2.5	155
RACD1502	150	2	61.26	31.47	9533	10	12	12	3.5	2.5	2.5	101
RACD1506	150	6	183.73	31.47	9533	14	20	12	3.5	2.5	2.5	141
RACD15010	150	10	306.3	31.47	9533	18	28	12	3.5	2.5	2.5	180



P140 Model Shown

PRODUCT LINE OVERVIEW

► Wide Variety

Simplex offers the widest selection of hand pump styles, reservoir sizes, and flow rates to meet your everyday needs. Each pump has specific features that make certain models better suited for particular jobs. Select a hand pump with features that best fit your application.

► Built for Rugged Industrial/Construction Use

Shipyards, steel mills, construction sites and weld shops can be rough environments for hand pumps. Simplex's all metal and aluminum designs withstand real world conditions and applications.

► Total Control of Hand Pump Operation

Simplex release valves have a fine pitch screw and large valve handle for maximum control. Check ball valve design is more reliable than needle valves, and less costly to repair.

► Lowest Handle Effort

Simplex hand pumps have low, back saving handle efforts to reduce operator fatigue & back injury.

► Optimal Oil Displacement Per Stroke

More oil per stroke means less handle strokes per job. Simplex pumps have the highest available oil displacement per stroke, in many cases reducing the number of handle strokes as much as 50%.

► Easy To Use / Built To Last

Pivot linkage provides uniform handle effort at all points along the arc of the pump handle stroke. The pivot reduces piston side loading for longer pump life. Some pump models have four-way valves for use with double-acting cylinders.

HAND PUMPS

Proper Size & Selection

SIMPLEX

Portable Hand Pumps



Single & two speed compact hand pumps deliver a constant flow to smaller cylinders or hydraulic powered tools regardless of load. Ideal when durability as well as portability are important.

Aluminum Hand Pumps

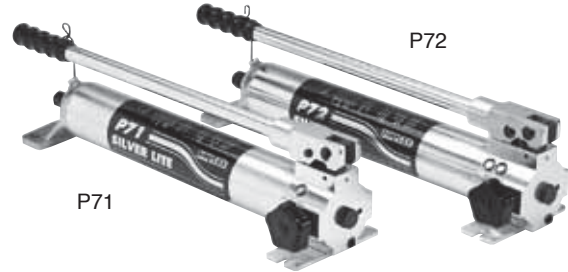

Aluminum hand pumps are the perfect choice when a light weight pump is required. The alloy construction resists corrosion and stands up to heat, welding sparks and other environments where composite pumps may not be suited.

Heavy Duty Hand Pumps



Heavy duty, two speed hand pumps in the low pressure stage deliver a high volume of oil per stroke for fast cylinder speed. Once the load is engaged, the pump automatically switches to the high pressure stage.

Specialty Hand Pumps



Specialty hand pumps are perfect for OEM applications or as emergency backup pumps. The pumps were designed to fit in tight spaces and are ideal for fixed bolt down applications.

Hi-Flow Hand Pumps With Large Reservoirs



Heavy duty hand pumps with 4 way valves are used to power double-acting cylinders or tools.

Configured Sets



Standard hand pump and single acting cylinder configuration.

Sizing The Proper Hand Pump To Your Cylinder

Once you have selected your cylinder, find the required reservoir capacity in the cylinder specification chart, and choose a hand pump with at least 10% more reservoir capacity per cylinder.

Example

An R256 cylinder (page 11) has a required oil capacity of 32.2 cu. in. The P42 hand pump (page 34) with a reservoir capacity of 45 cu.in. can pump this cylinder to its full stroke. If two R256 cylinders are to be raised, use a P140 with a reservoir capacity of 175 cu.in. .25" I.D. hose requires .6 cu. in. oil per foot. .38" I.D. hose requires 1.3 cu. in. per foot.

Type Of Cylinders

Most hand pumps are designed to operate single-acting cylinders. Hand pumps with 4-way valves can operate double-acting cylinders.

Quick Reference Chart

Use this chart to match the appropriate size hand pump to your single-acting Simplex cylinders. Match your cylinder capacity (across the top) with the cylinder strokes listed (in the left hand column). The intersecting box will give you the recommended hand pump for general applications.

Cylinder Stroke (in)	Cylinder Capacity (Tons)										
	5 Ton	10 Ton	15 Ton	20 Ton	25 Ton	30 Ton	50/55 Ton	60 Ton	75 Ton	100 Ton	150 Ton
1	P22/P32	P22/P32	----	P41A/P71	P42/P72	P42/P72	P42/P72	----	P42/P72	P42/P72	P42/P72
2	----	P22/P32	P42/P72	P42/P72	P42/P72	P42/P72	P42/P72	----	----	P82A/P140	P140
3	P22/P32	----	----	----	----	----	----	P82A/P140	----	----	----
4	----	P22/P32	P42/P72	----	P42/P72	----	----	----	----	----	----
5	P22/P32	----	----	----	----	----	----	----	----	----	----
6	----	P42/P72	P42/P72	----	P42/P72	P82A/P140	P82A/P140	----	P82A/P140	P230	P230
7	P42/P72	----	----	----	----	----	----	----	----	----	----
8	----	P42/P72	P42/P72	----	P82A/P140	P82A/P140	----	----	----	P230	P300
9	P42/P72	----	----	----	----	----	----	----	----	----	----
10	----	P42/P72	P42/P72	----	P82A/P140	----	----	----	----	P230	P461
12	----	P42/P72	----	----	P82A/P140	----	----	----	----	----	----
13	----	----	----	----	----	----	P230	----	----	----	----
14	----	P42/P72	P82A/P140	----	P82A/P140	----	----	----	----	----	----

For higher speeds, use power pumps to operate multiple cylinder systems or long stroke cylinders over 50 tons.

Hand Pump / Cylinder Speed Chart

Use this chart to determine the number of full pump handle strokes required to extend a Simplex cylinder 1". You may take handle stroke per inch and multiply it by the cylinder stroke to determine the number of strokes required to fully extend the cylinder.

Cylinder Stroke (in)	Strokes Per 1" of Cylinder Travel	Cylinder Capacity (Tons)									
		5 Ton	10 Ton	15 Ton	20 Ton	25 Ton	30 Ton	50/55 Ton	60 Ton	75 Ton	100 Ton
P41A/P71	NO LOAD	7	15	21	31	34	43	73	88	106	137
	LOAD	7	15	21	31	34	43	73	88	106	137
P20/P42/P32/P82A	NO LOAD	2	3	4	6	7	8	14	17	20	26
	LOAD	7	15	21	31	34	43	73	88	106	137
P72/P30	NO LOAD	2	3	4	6	7	8	13	16	18	23
	LOAD	7	15	21	31	34	43	73	88	106	137
P140/P300	NO LOAD	1	1	2	2	2	3	5	5	6	8
	LOAD	4	10	14	22	22	27	46	58	66	86
P230/P461	NO LOAD	1	1	1	1	1	1	2	2	2	3
	LOAD	3	8	11	16	18	22	38	45	54	70

HAND PUMPS

P Series - Compact Steel

SIMPLEX



P82A, P41A & P22 Shown

Reservoir Capacity▶ 20 - 134 cu.in.
 Weight▶ 10 - 24 lbs.
 Maximum Pressure▶ 10,000 psi

- ▶ Large 3/8" pressure port for maximum flow.
- ▶ Low handle effort for easy operation.
- ▶ Single and two speed models.
- ▶ Two-speed operation for fast and easy operation.
- ▶ Vent free reservoir eliminates spills (P41A).
- ▶ Chrome plated plunger and wiper system for durable, long lasting performance.

GAUGES - page 77



Improve your system visibility and safety by adding an inline hydraulic gauge to your circuit.

COUPLERS - pages 74 - 75



High flow quick disconnect couplers provide a quick change to a variety of pumps.

HOSES - pages 78 - 79



Heavy duty and thermo plastic hydraulic hoses to meet your requirements and safety factor.

With its compact footprint, the Simplex P22 hand pump is perfect for fixed mounting. ▼

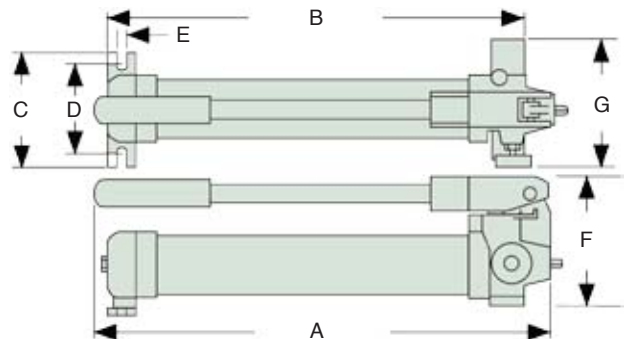

Model	Speed	Pressure Rating (PSI)	Oil Volume Per Stroke (cu.in.)		Usable Oil Capacity (cu.in.)	A	B	C	D	E	F	G	Wgt. (lbs)
			1st Stage	2nd Stage		(in)	(in)	(in)	(in)	(in)	(in)	(in)	
P20	2	1st Stage 200 2nd Stage 2,850	.79	.16	20	14.23	11.08	2.62	1.5	.59	5.59	5.39	10
P22	2	1st Stage 200 2nd Stage 10,000	.23	.06	20	14.23	11.08	2.62	1.5	.59	5.06	4.92	10
P41A	1	10,000	----	.16	40	23.03	18.28	5.25	---	---	4.69	4.00	13
P42	2	1st Stage 200 2nd Stage 10,000	.79	.16	45	25.64	20.86	3.54	---	---	5.75	5.39	19
P82A	2	1st Stage 350 2nd Stage 10,000	.99	.15	134	21.97	19.50	5.75	4.76	.31	6.88	7.00	24



P32 & P72 Shown

Reservoir Capacity▶ 30 - 70 cu.in.
 Weight▶ 8 - 11 lbs.
 Maximum Pressure▶ 10,000 psi

- ▶ All aluminum construction makes these pumps extremely light weight and easy to handle.
- ▶ 25% faster per stroke than comparative pumps means less work for operator.



RELEASE KNOB
 Precise load lowering with large knob and fine pitched threads.



POWER PUMPS - pages 43 - 65
 Simplex offers a wide variety of lightweight power pumps to fit any application.

This P32 provided the power and control to lift this 10 ton CNC machine during routine maintenance. ▼

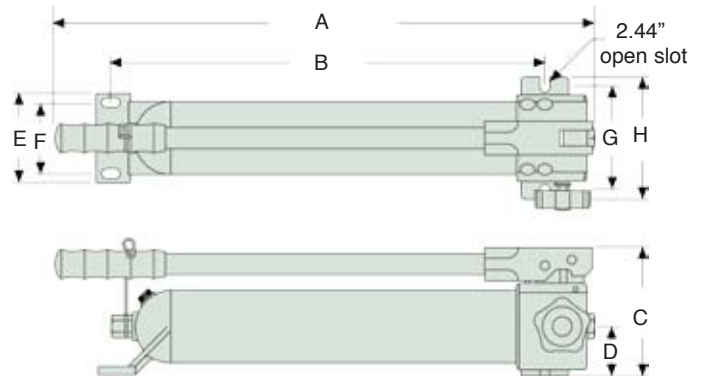

Model	Speed	Pressure Rating (PSI)	Oil Volume Per Stroke (cu.in.)	Usable Oil Capacity (cu.in.)	A	B	C	D	E	F	G	H	Wgt. (lbs)
					(in)	(in)	(in)	(in)	(in)	(in)	(in)	(in)	
P30	2	1st Stage 200 2nd Stage 3,000	.91	30	17.13	11.81	5.55	2	5.51	4.25	4.25	5.5	8
			.19										
P32	2	1st Stage 200 2nd Stage 10,000	.43	30	17.13	11.81	5.55	2	5.51	4.25	4.25	5.5	8
			.06										
P71	1	10,000	.14	70	24.60	19.35	5.55	2	5.51	4.25	4.25	5.5	10
P71V*	1	10,000	.14	70	24.60	19.35	5.55	2	5.51	4.25	4.25	5.5	10
P72	2	1st Stage 200 2nd Stage 10,000	.91	70	24.60	19.35	5.55	2	5.51	4.25	4.25	5.5	11
			.19										

*Viton Seals

HAND PUMPS

P Series - Heavy Duty Steel

SIMPLEX



P140 & P461D Shown

Reservoir Capacity► 175 - 460 cu.in.
 Weight► 26 - 61 lbs.
 Maximum Pressure► 10,000 psi

- Heavy duty, metal construction for durability.
- High displacements of oil per stroke.
- Adjustable handle effort / dual pivot points.
- Low, back saving handle effort.
- External adjustable relief valves.

Hand Pumps



THINK SAFETY

Please refer to pages 4&5 for a complete list of safety tips and recommendations.

P140 & P300 Series

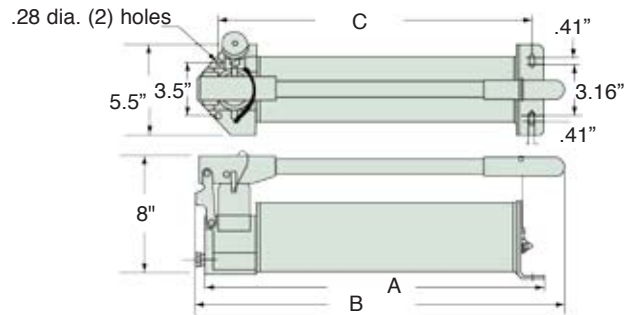

P230 & P461 Series

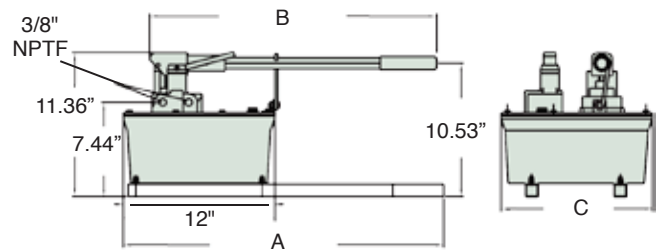

US recovery teams needed to dismantle and remove a downed Navy aircraft, they used Simplex P140D hand pumps. ▼



Model	Tool Type	Pressure Rating (PSI)	Oil Volume Per Stroke (cu.in.)		Usable Oil Capacity (cu.in.)	A	B	C	Wgt. (lbs)
			1st Stage	2nd Stage		(in)	(in)	(in)	
P140	Single Acting	1st Stage 400 2nd Stage 10,000	2.8	.24	175	24.81	27.25	23.31	26
P230			7.7	.3	230	25.38	22.75	9	49
P300			2.8	.24	300	28.5	31	26.5	37
P461			7.7	.3	460	25.38	22.75	12	61
P140D	Double Acting	1st Stage 400 2nd Stage 10,000	2.8	.24	175	29.5	31.5	23.31	30
P230D			7.7	.3	230	25.38	22.75	9	49
P300D			2.8	.24	300	32.68	34.68	26.5	41
P461D			7.7	.3	460	25.38	22.75	12	61



P10004A & P1606A Shown

Volume Per Stroke ▶ .30 - 4.56 cu.in.
 Weight ▶ 9 - 20 lbs.
 Pressure Range ▶ 750 - 12,000 psi

- ▶ Ideal for fixed applications when pumps need to be bolted in place.
- ▶ P1000A Series offers a swivel pump head for flexible fixturing.
- ▶ Wide range of operating pressures to select from.

P160A Series

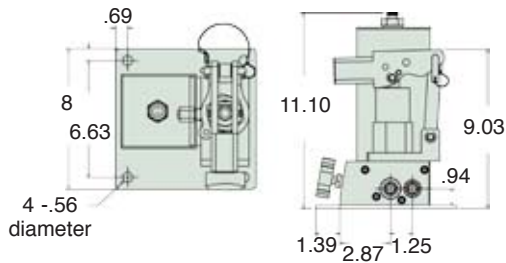

P1000A Series

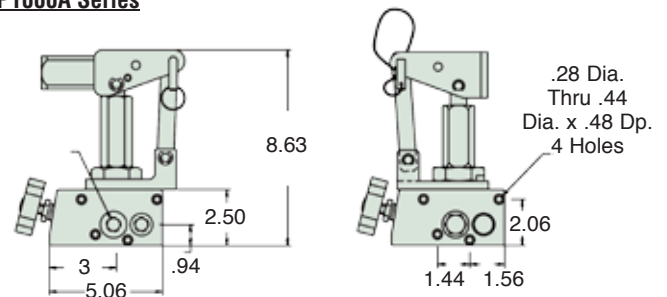

This P10006A is used as an auxiliary pump to position scaffolding for fabrication of the docking system for a new airline hangar. ▼

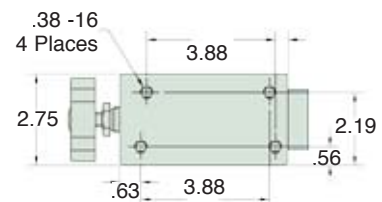

Model	Usable Reservoir Capacity (cu.in.)	Operating Pressure (PSI)	Volume per Stroke (cu.in.)	Maximum Handle Effort (lbs)	Weight (lbs)
P1603A	148	12,000	.30	108	20
P1604A	148	6,500	.53	104	20
P1606A	148	3,000	1.33	108	20
P10003A	---	12,000	.30	108	9
P10004A	---	6,500	.53	104	9
P10006A	---	3,000	1.33	108	9
P10008A	---	1,000	2.11	106	11
P100012A	---	750	4.56	79	11

HAND PUMPS

P Series - Ultra High Pressure Aluminum

SIMPLEX



Reservoir Capacity▶ 60 cu.in.
 Weight▶ 10 lbs.
 Maximum Pressure▶ 40,000 psi

- ▶ 40,000 psi maximum pressure.
- ▶ 60 cu. in. reservoir provides more usable oil capacity.
- ▶ Large pressure release knob, fine threaded for added control.
- ▶ Lower handle effort provides less operator fatigue.
- ▶ Slotted front mounting hole offers flexibility.

P60 Shown

Hand Pumps



THINK SAFETY

Please refer to pages 4&5 for a complete list of safety tips and recommendations.



SPRING LATCH

An easy to use spring latch handle provides quick carrying mobility.

Pressure Port Details

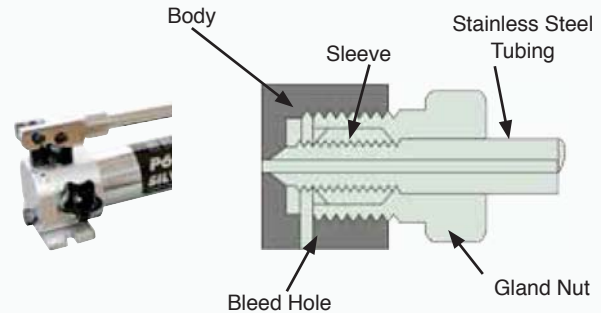

▲ Cone Seal

High pressure fitting seal on a cone surface does not require pipe sealer. The gland nut holds the sleeve and tube to provide 40,000 psi seal.



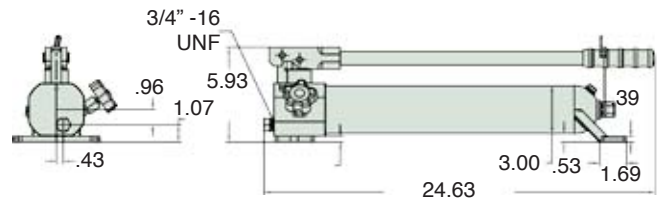
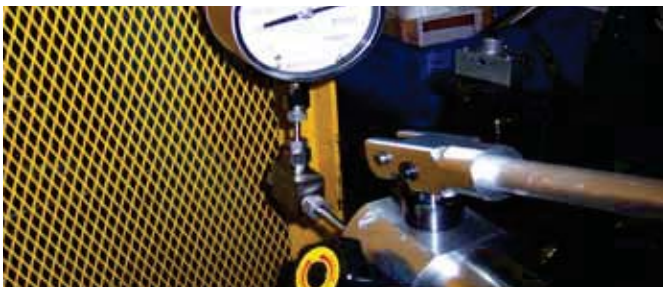





Ideal for lab testing, the P60 offers safe and easy operation for applications requiring up to 40,000 psi. ▼



Model	Usable Reservoir Capacity (cu.in.)	Pressure Rating (PSI)		Oil Volume Per Stroke (cu.in.)		Handle Effort (lbs)	Weight (lbs)
		1st Stage	2nd Stage	1st Stage	2nd Stage		
P60	60	200	40,000	.86	.04	90	10

Note: .25" cone fittings use .56" - 18 threads, .38" cone fittings use .75" - 16 . * Actual tubing lengths are .75" less than nominal size shown. These dimensions make distance between centers of valves and fittings multiple of 4" spaces.

P60 ULTRA HIGH PRESSURE ACCESSORIES

Model	Item No.	Connection
 Gland Nut Plug	UH1	.38" Cone
 Elbow	UH2	.38" Cone
 Tee	UH3	.38" Cone Side
 Gauge Adapter	UH4	.38" Cone Side / .25" Cone Gauge Port
 Coupling	UH5	.38" Cone
 Gland Nut with Sleeve	UH6	.38" Cone
 Gauge Connector	UH7	.25" Cone
 Gauge	UH8	0 - 40,000 psi (2,760 Bar) Ultra High Pressure Gauge
 Tubing	UH9 UH10 UH11	4" Tube, O.D. .38" * 8" Tube, O.D. .38" * 12" Tube, O.D. .38" *

PUMP & CYLINDER SETS

ST & STL Series - Steel & Aluminum

SIMPLEX



ST106A Set Shown

Capacity Range▶ 10 - 100 tons

Stroke Range▶ 15 - 14.25 in.

Maximum Pressure▶ 10,000 psi

- ▶ Each set comes with a 6' hose equipped with a high flow coupler, gauge and gauge adapter.
- ▶ Cylinders can be used in upright, inverted or horizontal position.
- ▶ Maximum control and safety is provided with the pressure gauge.
- ▶ Optimal performance provided with matched pump and cylinder.

Hand Pumps



THINK SAFETY

Please refer to pages 4&5 for a complete list of safety tips and recommendations.

Each Set Includes The Following:

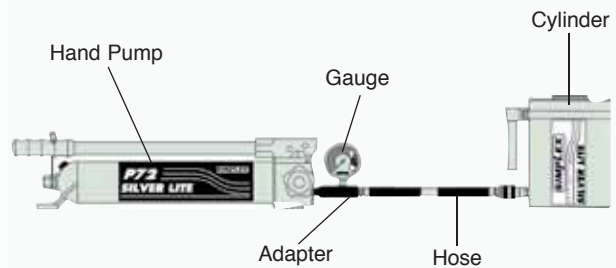

Eliminate the hassle of matching the right pump to the right cylinder by ordering our pre-matched pump & cylinder sets. ▼

Pump and cylinder sets are ideal for shop equipment servicing, such as this scrap metal receptacle requiring maintenance. ▼



Steel Hand Pumps

Center Hole Cylinder Sets

Model	Capacity (tons)	Stroke (in)	Closed Height (in)	Included in Set				
				Cylinder Model	Pump Model	Hose	Gauge	Gauge Adapter
ST302HCA	30	2.5	7.03	RC302A	P42	HCA6	GTH12	GA1
ST306HCA	30	6.13	13	RC306A	P82A	HCA6	GTH12	GA1

Low Profile Cylinder Sets

Model	Capacity (tons)	Stroke (in)	Closed Height (in)	Included in Set				
				Cylinder Model	Pump Model	Hose	Gauge	Gauge Adapter
ST101A	10	1.5	3.47	RLS101	P42	HCA6	GT5	GA1
ST201A	20	1.75	3.87	RLS201	P42	HCA6	GT20	GA1
ST302A	30	2.44	4.62	RLS302	P42	HCA6	GT30	GA1
ST502A	50	2.38	4.81	RLS502	P42	HCA6	GT20	GA1
ST1002A	100	2.25	5.56	RLS1002	P82A	HCA6	GT20	GA1

General Purpose Cylinder Sets

Model	Capacity (tons)	Stroke (in)	Closed Height (in)	Included in Set				
				Cylinder Model	Pump Model	Hose	Gauge	Gauge Adapter
ST102A	10	2.19	4.78	R102	P42	HCA6	GT5	GA1
ST106A	10	6	9.78	R106	P42	HCA6	GT5	GA1
ST1010A	10	10	13.78	R1010	P42	HCA6	GT5	GA1
ST252A	25	2	6.5	R252	P42	HCA6	GT25	GA1
ST254A	25	4	8.5	R254	P42	HCA6	GT25	GA1
ST256A	25	6.19	10.75	R256	P82A	HCA6	GT25	GA1
ST2514A	25	14.19	18.75	R2514	P82A	HCA6	GT25	GA1
ST556A	55	6.19	11.06	R556	P82A	HCA6	GT25	GA1

Aluminum Hand Pumps

Silver Lite Aluminum Spring Return Sets

Model	Capacity (tons)	Stroke (in)	Closed Height (in)	Included in Set				
				Cylinder Model	Pump Model	Hose	Gauge	Gauge Adapter
STL302	30	2	6.5	RAS302B	P72	HCA6	G5	GA1
STL306	30	6	10.5	RAS306B	P72	HCA6	G5	GA1
STL502	50	2	6.5	RAS502B	P72	HCA6	G5	GA1
STL504	50	4	8.5	RAS504B	P72	HCA6	G5	GA1
STL1002	100	2	6.5	RAS1002B	P72	HCA6	G5	GA1

Silver Lite Aluminum Spring Return Center Hole Sets

Model	Capacity (tons)	Stroke (in)	Closed Height (in)	Included in Set				
				Cylinder Model	Pump Model	Hose	Gauge	Gauge Adapter
STL303HC	30	3	8.75	RAC303	P72	HCA6	G5	GA1
STL306HC	30	6	11.75	RAC306	P72	HCA6	G5	GA1
STL603HC	60	3	10.13	RAC603	P72	HCA6	G5	GA1

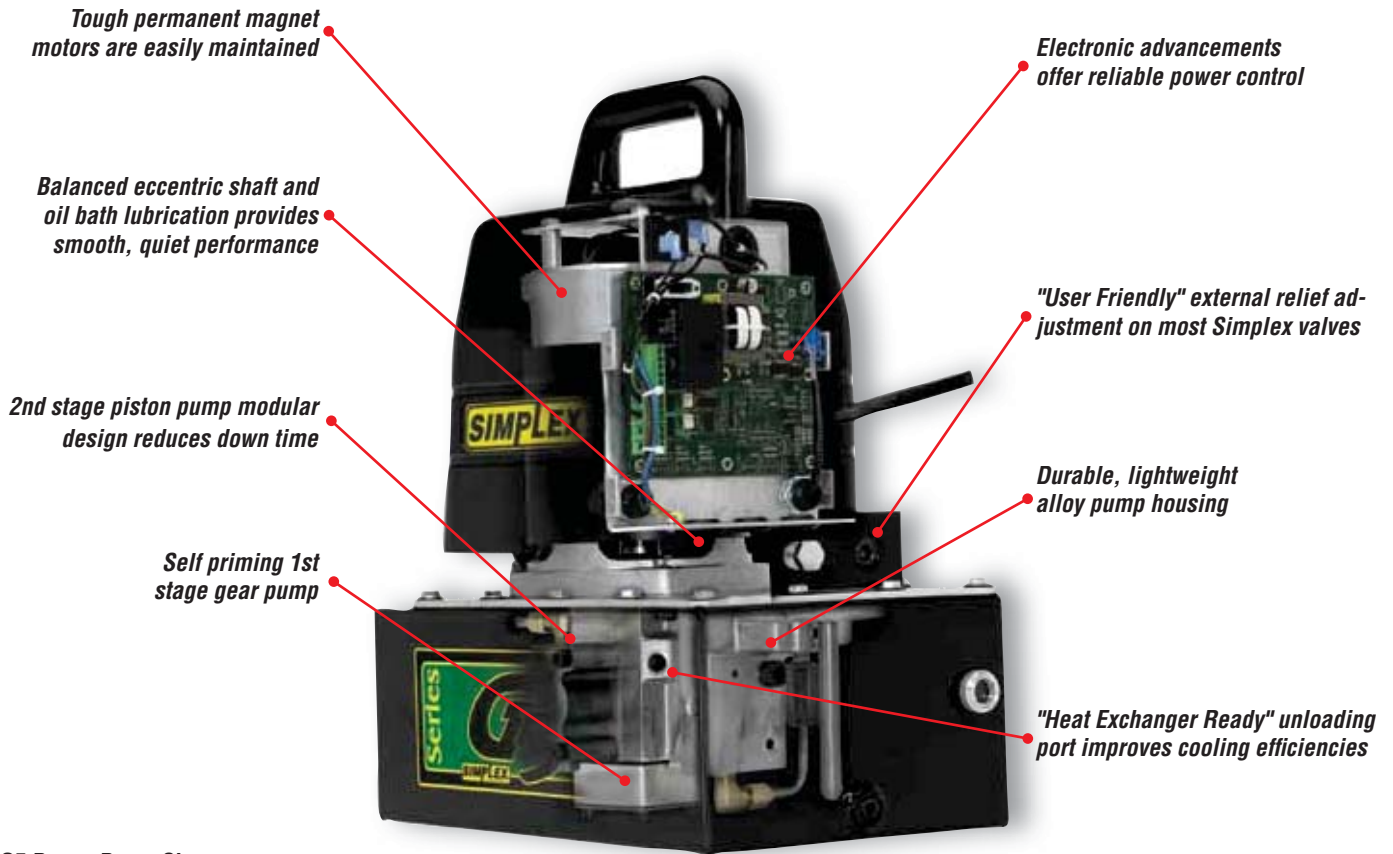

G5 Power Pump Shown

PRODUCT LINE OVERVIEW

► **Wide Variety**

Simplex offers a large selection of pump platforms, valve styles, reservoir sizes, accessories & controls to meet your everyday needs.

► **Maximum Flexibility**

External adjustable pressure relief valves for variable pressure settings, plus many interchangeable control valves and reservoirs for a wide range of applications. Dual Voltage & Dual Hertz electric motors for applications requiring alternate power sources.

► **Built for Long Life & Continuous Duty**

Unified chassis provides high strength, fewer potential leak points and solid construction for severe duty.

► **High Performance / Fast Cycle Times**

Crossover pressure up to 2,000 psi. Provides high, first stage flows well into the work cycle. This extra power provides higher speeds in Prestressing, Bending, Crimping, Compressing & Post-Tensioning applications.

► **Cool Running & Dependable Performance**

High first stage performance is achieved through field proven Gear Pump technology. In addition to gear pumps, an unloading valve passes full power to the second stage once crossover pressure is reached. No power is lost and less heat is generated.

► **Quiet Operation**

Low motor RPM, internally lubricated bearings, and close coupled motor mounting make these pumps among the quietest on the market. (Approximately 80dba at 10,000 psi.)

POWER PUMPS

Proper Size & Selection

SIMPLEX

G1 Power Pumps

19 cu.in./min. @ 10,000 psi



An intermittent .5 hp power pump that is best suited to power small to medium size tools or cylinders. It's very lightweight, portable and works well for crimping, cutting, pressing, punching and bending applications.

G5 Power Pumps

55 cu.in./min. @ 10,000 psi



Continuous duty 1.5 hp electric and 3 hp air power pumps are perfect for medium size tools and cylinders on construction sites, ship and rail yards and other field applications. It's the perfect choice for production and lifting applications due to its reservoir sizes and valve options.

G3 Power Pumps

46 cu.in./min. @ 10,000 psi



A 1.13 hp continuous duty power pump that is best suited to power small to medium tools and cylinders. Ideal for systems that require high performance, large oil capacities with lightweight portability.

G6 Power Pumps

100 cu.in./min. @ 10,000 psi



Continuous duty 3 hp electric and 5.5 hp gasoline pumps are ideal for medium to large size tools and cylinders. The high flow rate runs multiple cylinders for heavy lifting, high tonnage and large positioning jobs and applications effectively.

G4 Power Pumps

55 cu.in./min. @ 10,000 psi







Continuous duty 1.5 hp electric and 4 hp gasoline pumps are best suited for medium size tools and cylinders. It's a perfect choice for clamping, holding, positioning and lowering and lifting applications due to its reservoir sizes and valve options.

Compact Air Foot Pumps

11 cu.in./min @ 10,000 psi

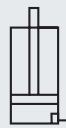

An intermittent portable foot controlled pump best suited for pressing, production and shop tool applications. Runs effectively on 10CFM @ 60-150 PSI.

Basic Valve Configurations For Pumps							
Pump Application	Valve Type	Valve Function			Works With Cylinder Type		
							
		Advance	Hold	Retract	Single-Acting Load RTN	Single-Acting Spring RTN	Double-Acting
Dump pumps are ideal for crimping, pressing or cutting applications. Switching motor "on" builds pressure, switching motor "off" dumps pressure.	Dump Valve	●	---	●	●	●	---
Manual valve pumps are ideal for general applications. Directional control is accomplished by manually shifting a control valve.	2 Way	●	---	●	●	●	---
	*3 Way	●	●	●	●	●	---
	4 Way	●	●	●	---	---	●
Solenoid valve pumps are ideal for production/automation applications. Directional control is accomplished via solenoid w/pendant.	2 Way	●	---	●	---	●	---
	*3 Way	●	●	●	●	●	---
	4 Way	●	●	●	---	---	●

* 3 Way Models Include Suc-O-Matic Feature

Simplex pumps are the world's only 10,000 psi pumps to offer a new standard in pump construction and reliability. Close coupled motor and the one piece chassis combine to offer a rigid unit with minimal flex and wear characteristics.

The chassis, field proven gear pumps, replaceable piston bores and ball seats, higher crossovers, and quality motors are just a few of the extras incorporated in all Simplex pumps.

Use the speed chart (right) and select the right size pump to obtain the cylinder speed you desire.

For multiple cylinder system speeds, divide the inches per minute by number of cylinders in the system.

Cylinder Capacity (Tons)	Inches Per Minute					
		G1 Series	G3 Series	G4/G5 Series	G6 Series	
10	Loaded	9	9	24	45	76
	Unloaded	104	169	169	200	290
20/25	Loaded	4	4	10	20	33
	Unloaded	50	75	75	132	132
30	Loaded	3	3	8.5	16	26
	Unloaded	39	60	60	104	104
50/55	Loaded	2	2	5	9	15
	Unloaded	23	35	35	61	61
60/75	Loaded	1.5	1.5	3.5	6	10
	Unloaded	16	24	24	43	43
100	Loaded	1	1	3	5	8.5
	Unloaded	13	19	19	34	34
150	Loaded	.5	.5	1.75	3	5
	Unloaded	7	11	11	20	20
200	Loaded	.38	.38	1	2	4
	Unloaded	5	8	8	15	15

$$\frac{\text{Inches Per Minute}}{60} = \text{Cylinder Speed In Seconds}$$



Model Shown G1131

Reservoir Capacity▶ 1 gallon
 Flow @ Rated Pressure▶ 19 cu.in./min.
 Maximum Pressure▶ 10,000 psi

- ▶ Powered by a 115V - 60HZ, .5 hp universal motor (14,640 rpm).
- ▶ Low startup voltage, draws 10 amps at full load (230V models available).
- ▶ Two-speed pump operation provides fast tool performance.
- ▶ External adjustable relief standard on all models.



SITE GAUGE

Metal reservoir site gauge for easy viewing of oil level.



COUPLERS - pages 74 - 75

High flow quick disconnect couplers provide a quick change to a variety of pumps.



HOSES - pages 78 - 79

Heavy duty and thermo plastic hydraulic hoses to meet your requirements and safety factor.



SUC-O-MATIC VALVE

The 3 position / 3 way "Suc-O-Matic" valve draws hydraulic oil out of any single acting cylinder with full retraction regardless of weak springs or mounting.



THINK SAFETY

Please refer to pages 4&5 for a complete list of safety tips and recommendations.

With its mobility and power, the G1 power pump with a low profile locknut cylinder was the perfect choice for adjusting loaded shelving racks in this warehouse. ▼

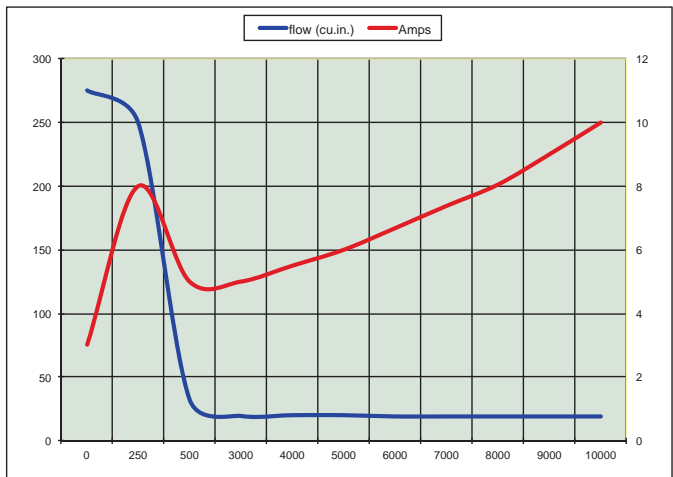

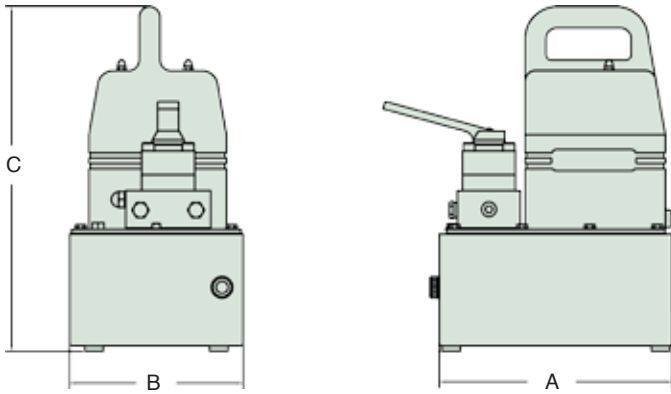

Reservoir (Gallons)	A	B	C
	(in)	(in)	(in)
1 Plastic	10.52	8.08	15.95
1 Metal	11.00	8.17	16.17

Model	Pressure Rating (psi)		Output Flow (cu.in. / min.)		Motor Spec.		Valve Type	Pendant Control	Usable Oil	Weight (lbs)
	1st Stage	2nd Stage	1st Stage	2nd Stage	(vac)	(amps)				
G1100	400	10,000	250	19	115	10	DUMP	MOTOR	1	30
G1101	400	10,000	250	19	115	10	DUMP	MOTOR	1	32
G1121	400	10,000	250	19	115	10	2W, 2P	MOTOR	1	33
G1131	400	10,000	250	19	115	10	3W, 3P	MOTOR	1	34
G1141	400	10,000	250	19	115	10	4W, 3P	MOTOR	1	34

* For 230 VAC pump use "2" in the 3rd character of the model number. Motor specifications 0,37 kw single phase, 5 amps @ 230 VAC.
 * Motor pendant is standard on all models.

Power Pumps

Additional Pump Configurations

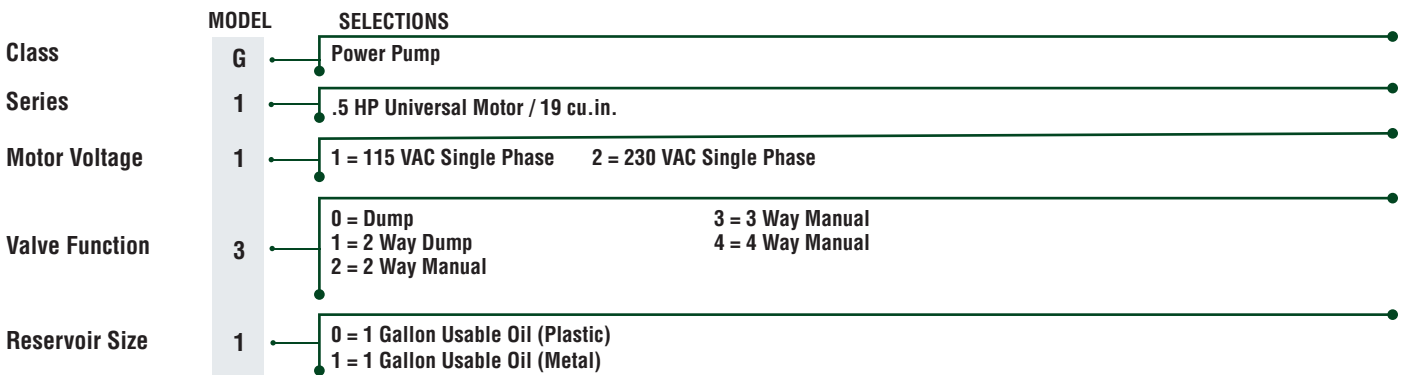

POWER PUMPS

G3 Series - Electric

SIMPLEX



G3132 Shown

Reservoir Capacity▶ 1 - 20 gallons
 Flow @ Rated Pressure.....▶ 46 cu.in./min.
 Maximum Pressure▶ 10,000 psi

- ▶ Powered by a 115V - 60Hz, 1.13 hp universal motor (21,000 rpm).
- ▶ Low startup voltage, draws 16 amps at full load (230V models available).
- ▶ Equipped with a 15' remote power controlled pendant.
- ▶ Reservoirs available in 1- 20 gallons; welded steel design.
- ▶ Ideal for use with small, mid sized hydraulic cylinders or tools.

Power Pumps



SITE GAUGE

Metal reservoir site gauge for easy viewing of oil level.



IN-LINE VALVES - page 72

Maximize control and safety with our in-line valves.



MANIFOLDS - page 73

The ideal solution in obtaining precise control when operating multiple cylinders.



SUC-O-MATIC VALVE

The 3 position / 3 way "Suc-O-Matic" valve draws hydraulic oil out of any single acting cylinder with full retraction regardless of weak springs or mounting.



THINK SAFETY

Please refer to pages 4&5 for a complete list of safety tips and recommendations.

A Simplex G3 power pump was used at a testing facility to pressurize manifolds for leaks. ▼

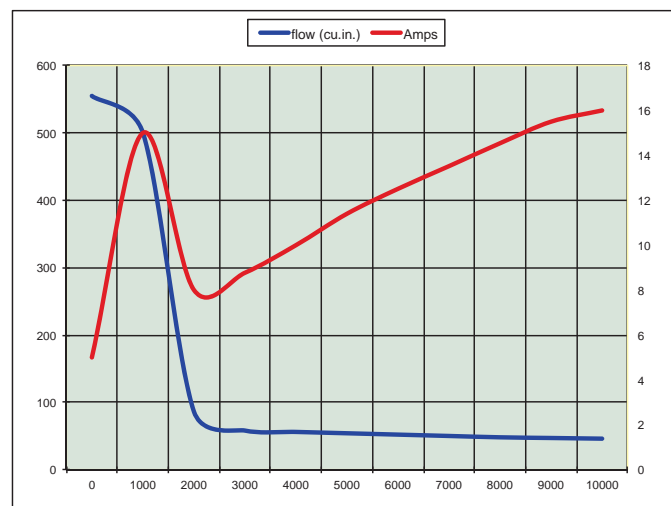

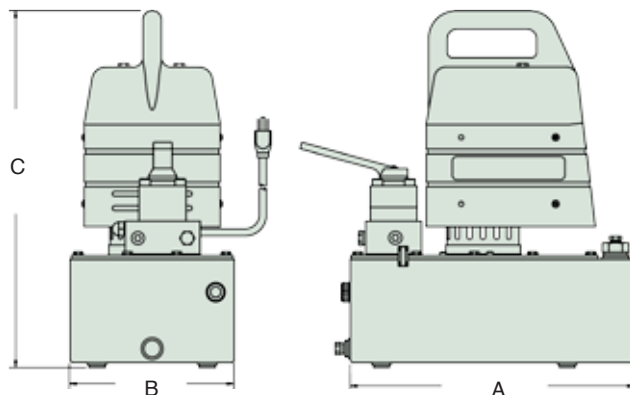

Reservoir (Gallons)	A	B	C
	(in)	(in)	(in)
1	11.00	8.19	18.75
1.5	15.13	8.75	19
2.5	17	9.75	19
5	25.10	11.75	18.75
10	25.10	11.75	23
20	28	19.6	25.25

Model	Pressure Rating (psi)		Output Flow (cu.in./min.)		Motor Spec.		Valve Type	Pendant Control	Usable Oil	Weight (lbs)
	1st Stage	2nd Stage	1st Stage	2nd Stage	(vac)	(amps)				
G3100	1,100	10,000	525	46	115	16	Dump	Motor	1	38
G3101	1,100	10,000	525	46	115	16	Dump	Motor	1	45
G3102	1,100	10,000	525	46	115	16	Dump	Motor	1.5	50
G3121	1,100	10,000	525	46	115	16	2W, 2P	Motor	1	45
G3122	1,100	10,000	525	46	115	16	2W, 2P	Motor	1.5	52
G3131	1,100	10,000	525	46	115	16	3W, 3P	Motor	1	48
G3132	1,100	10,000	525	46	115	16	3W, 3P	Motor	1.5	53
G3133	1,100	10,000	525	46	115	16	3W, 3P	Motor	2.5	63
G3162	1,100	10,000	525	46	115	16	3W, 3P	Motor / Solenoid	1.5	57
G3163	1,100	10,000	525	46	115	16	3W, 3P	Motor / Solenoid	2.5	67
G3141	1,100	10,000	525	46	115	16	4W, 3P	Motor	1	48
G3142	1,100	10,000	525	46	115	16	4W, 3P	Motor	1.5	53
G3143	1,100	10,000	525	46	115	16	4W, 3P	Motor	2.5	63
G3172	1,100	10,000	525	46	115	16	4W, 3P	Motor / Solenoid	1.5	57
G3173	1,100	10,000	525	46	115	16	4W, 3P	Motor / Solenoid	2.5	67

* For 230 VAC pump use "2" in the 3rd character of the model number. Motor specifications 0,8 kw single phase, 10 amps @ 230 VAC.

Additional Pump Configurations

MODEL	SELECTIONS									
Class	G Power Pump									
Series	3 1.13 HP Universal Motor / 46 cu.in.									
Motor Voltage	1 1 = 115 VAC Single Phase 2 = 230 VAC Single Phase									
Valve Function	<table border="0"> <tr> <td>0 = Dump</td> <td>3 = 3 Way Manual</td> <td>7 = 4 Way Solenoid</td> </tr> <tr> <td>1 = 2 Way Dump</td> <td>4 = 4 Way Manual</td> <td></td> </tr> <tr> <td>2 = 2 Way Manual</td> <td>6 = 3 Way Solenoid</td> <td></td> </tr> </table>	0 = Dump	3 = 3 Way Manual	7 = 4 Way Solenoid	1 = 2 Way Dump	4 = 4 Way Manual		2 = 2 Way Manual	6 = 3 Way Solenoid	
0 = Dump	3 = 3 Way Manual	7 = 4 Way Solenoid								
1 = 2 Way Dump	4 = 4 Way Manual									
2 = 2 Way Manual	6 = 3 Way Solenoid									
Reservoir Size	<table border="0"> <tr> <td>1 = 1 Gallon Usable Oil</td> <td>3 = 2.5 Gallons Usable Oil</td> <td>6 = 10 Gallons Usable Oil</td> </tr> <tr> <td>2 = 1.5 Gallons Usable Oil</td> <td>5 = 5 Gallons Usable Oil</td> <td>7 = 20 Gallons Usable Oil</td> </tr> </table>	1 = 1 Gallon Usable Oil	3 = 2.5 Gallons Usable Oil	6 = 10 Gallons Usable Oil	2 = 1.5 Gallons Usable Oil	5 = 5 Gallons Usable Oil	7 = 20 Gallons Usable Oil			
1 = 1 Gallon Usable Oil	3 = 2.5 Gallons Usable Oil	6 = 10 Gallons Usable Oil								
2 = 1.5 Gallons Usable Oil	5 = 5 Gallons Usable Oil	7 = 20 Gallons Usable Oil								
Factory Installed Options*	<table border="0"> <tr> <td>G C = Caster Wheel Kit</td> <td>L = Locking Style Manifold</td> <td>R = Roll Cage</td> </tr> <tr> <td>F = Foot Switch (Motor)</td> <td>O = Oil Filter</td> <td>S = Foot Switch (Valve)</td> </tr> <tr> <td>G = Pump Mounted Gauge</td> <td>P = Pressure Switch</td> <td></td> </tr> </table>	G C = Caster Wheel Kit	L = Locking Style Manifold	R = Roll Cage	F = Foot Switch (Motor)	O = Oil Filter	S = Foot Switch (Valve)	G = Pump Mounted Gauge	P = Pressure Switch	
G C = Caster Wheel Kit	L = Locking Style Manifold	R = Roll Cage								
F = Foot Switch (Motor)	O = Oil Filter	S = Foot Switch (Valve)								
G = Pump Mounted Gauge	P = Pressure Switch									

- * If pump model consists of more than 3 options, contact factory. * Motor pendant is standard on all models.
- * Gauge will not be protected by roll cage when a 5 gallon or larger reservoir is ordered.
- * Roll cage not available on 10 & 20 gallon reservoir.
- * Caster wheel kit not available on 5,10 & 20 gallon reservoirs.
- * Oil filter not available on dump, 2 way dump & 2 way manual.

POWER PUMPS

G4 Series - Electric

SIMPLEX

G4
Electric



G4173 Shown

Reservoir Capacity► 1.5 - 20 gallons

Flow @ Rated Pressure► 55 cu.in./min.

Maximum Pressure► 10,000 psi

- Powered by a 115V - 60Hz, 1.5 hp induction motor (1,725 rpm).
- Low startup voltage, draws amps at full load (230V models available).
- High performance two-stage pump provides higher cross-over pressure for faster cycle times and equipment operation.
- Ideal for use with mid sized hydraulic cylinders.

Power Pumps



CYLINDERS - pages 7 - 29

A large selection of steel and aluminum cylinders to meet every need.



COUPLERS - pages 74 - 75

High flow quick disconnect couplers provide a quick change to a variety of pumps.



MANIFOLDS - page 73

The ideal solution in obtaining precise control when operating multiple cylinders.



SUC-O-MATIC VALVE

The 3 position / 3 way "Suc-O-Matic" valve draws hydraulic oil out of any single acting cylinder with full retraction regardless of weak springs or mounting.



THINK SAFETY

Please refer to pages 4&5 for a complete list of safety tips and recommendations.

The Simplex G4 power pump along with the S3000A spreader was used to pry apart the rusted doors on this steel shipping container. ▼

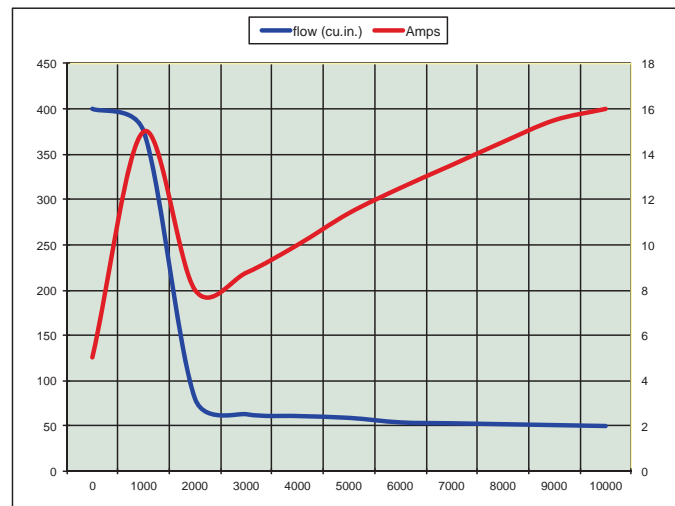

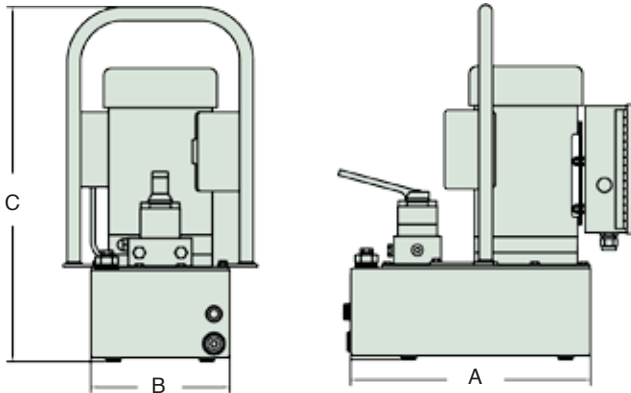

Reservoir (Gallons)	A	B	C
	(in)	(in)	(in)
1.5	15.13	8.75	22.34
2.5	17	9.75	22.34
5	25.10	11.75	21
10	25.10	11.75	25.25
20	28	19.6	25.25

Model	Pressure Rating (psi)		Output Flow (cu.in./min.)		Motor Spec.		Valve Type	Pendant Control	Usable Oil	Weight (lbs)
	1st Stage	2nd Stage	1st Stage	2nd Stage	(vac)	(amps)				
G4102	1,100	10,000	400	55	115	16	Dump	Motor	1.5	38
G4103	1,100	10,000	400	55	115	16	Dump	Motor	2.5	45
G4122	1,100	10,000	400	55	115	16	2W, 2P	Optional Motor	1.5	52
G4132	1,100	10,000	400	55	115	16	3W, 3P	Optional Motor	1.5	53
G4133	1,100	10,000	400	55	115	16	3W, 3P	Optional Motor	2.5	63
G4162	1,100	10,000	400	55	115	16	3W, 3P	Motor / Solenoid	1.5	57
G4163	1,100	10,000	400	55	115	16	3W, 3P	Motor / Solenoid	2.5	67
G4142	1,100	10,000	400	55	115	16	4W, 3P	Optional Motor	1.5	53
G4143	1,100	10,000	400	55	115	16	4W, 3P	Optional Motor	2.5	63
G4172	1,100	10,000	400	55	115	16	4W, 3P	Motor / Solenoid	1.5	57
G4173	1,100	10,000	400	55	115	16	4W, 3P	Motor / Solenoid	2.5	67

* For 230 VAC pump use "2" in the 3rd character of the model number. Motor specifications 1,1 kw single phase, 10 amps @ 230 VAC.

Additional Pump Configurations

MODEL	SELECTIONS
Class	G — Power Pump
Series	4 — 1.5 HP Induction Motor / 55 cu.in.
Motor Voltage	1 — 1 = 115 VAC Single Phase 2 = 230 VAC Single Phase
Valve Function	3 — 0 = Dump 1 = 2 Way Dump 2 = 2 Way Manual 3 = 3 Way Manual 4 = 4 Way Manual 6 = 3 Way Solenoid 7 = 4 Way Solenoid
Reservoir Size	2 — 2 = 1.5 Gallons Usable Oil 3 = 2.5 Gallons Usable Oil 5 = 5 Gallons Usable Oil 6 = 10 Gallons Usable Oil 7 = 20 Gallons Usable Oil
Factory Installed Options*	G — C = Caster Wheel Kit F = Foot Switch (Motor) G = Pump Mounted Gauge H = Heat Exchanger L = Locking Style Manifold M = Motor Pendant O = Oil Filter P = Pressure Switch R = Roll Cage S = Foot Switch (Valve)

* If pump model consists of more than 3 options, contact factory.
 * Gauge will not be protected by roll cage when a 5 gallon or larger reservoir is ordered.
 * Roll cage not available on 10 & 20 gallon reservoir.
 * Caster wheel kit not available on 5,10 & 20 gallon reservoirs.
 * Oil filter not available on dump, 2 way dump & 2 way manual.



G5132G Shown

Reservoir Capacity► 1.5 - 20 gallons

Flow @ Rated Pressure► 55 cu.in./min.

Maximum Pressure► 10,000 psi

- Powered by a 115V - 60Hz, 1.5 hp permanent magnet motor (3,000 rpm).
- Low startup voltage, draws 18 amps at full load (230V models available).
- High performance two-stage pump provides higher cross-over pressure for faster cycle times.
- Ideal for use with mid to large sized hydraulic cylinders or tools.
- Comes standard with 15' pendant.



CYLINDERS - pages 7 - 29

A large selection of steel and aluminum cylinders to meet every need.



HOSES - pages 78 - 79

Heavy duty and thermo plastic hydraulic hoses to meet your requirements and safety factor.



IN-LINE VALVES - page 72

Maximize control and safety with our in-line valves.



SUC-O-MATIC VALVE

The 3 position / 3 way "Suc-O-Matic" valve draws hydraulic oil out of any single acting cylinder with full retraction regardless of weak springs or mounting.

THINK SAFETY

Please refer to pages 4&5 for a complete list of safety tips and recommendations.



The G5 power pump coupled with a 50 ton Simplex cylinder are used daily to position bearings in the assembly processing section of the plant. ▼

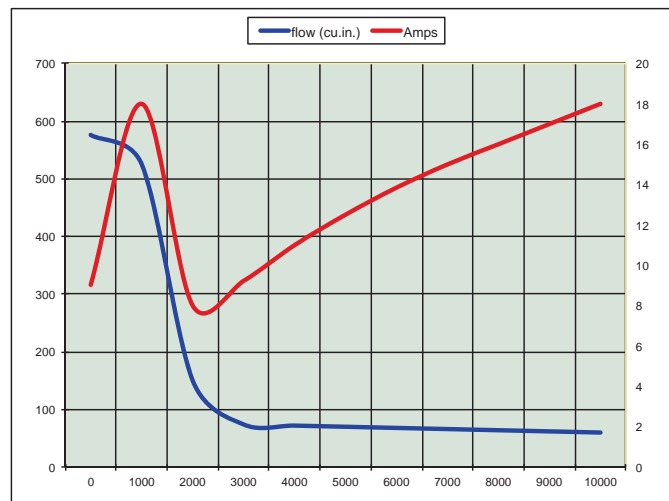

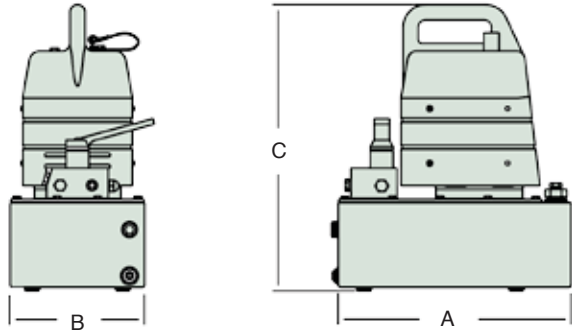

Reservoir (Gallons)	A	B	C
	(in)	(in)	(in)
1.5	15.13	8.75	18.59
2.5	17	9.75	18.59
5	25.10	11.75	18.59
10	25.10	11.75	22.84
20	28	19.60	22.84



Model	Pressure Rating (psi)		Output Flow (cu.in./min.)		Motor Spec.		Valve Type	Pendant Control	Usable Oil	Weight (lbs)
	1st Stage	2nd Stage	1st Stage	2nd Stage	(vac)	(amps)				
G5102	1,100	10,000	550	55	115	18	Dump	Motor	1.5	64
G5103	1,100	10,000	550	55	115	18	Dump	Motor	2.5	74
G5122	1,100	10,000	550	55	115	18	2W, 2P	Motor	1.5	64
G5123	1,100	10,000	550	55	115	18	2W, 2P	Motor	2.5	74
G5132	1,100	10,000	550	55	115	18	3W, 3P	Motor	1.5	67
G5133	1,100	10,000	550	55	115	18	3W, 3P	Motor	2.5	77
G5135	1,100	10,000	550	55	115	18	3W, 3P	Motor	5	115
G5162	1,100	10,000	550	55	115	18	3W, 3P	Motor / Solenoid	1.5	71
G5163	1,100	10,000	550	55	115	18	3W, 3P	Motor / Solenoid	2.5	81
G5165	1,100	10,000	550	55	115	18	3W, 3P	Motor / Solenoid	5	119
G5142	1,100	10,000	550	55	115	18	4W, 3P	Motor	1.5	67
G5143	1,100	10,000	550	55	115	18	4W, 3P	Motor	2.5	77
G5145	1,100	10,000	550	55	115	18	4W, 3P	Motor	5	115
G5172	1,100	10,000	550	55	115	18	4W, 3P	Motor / Solenoid	1.5	71
G5173	1,100	10,000	550	55	115	18	4W, 3P	Motor / Solenoid	2.5	81
G5175	1,100	10,000	550	55	115	18	4W, 3P	Motor / Solenoid	5	119

* For 230 VAC pump use "2" in the 3rd character of the model number. Motor specifications 1,1 kw single phase, 10 amps @ 230 VAC.

Additional Pump Configurations

MODEL	SELECTIONS				
Class	G Power Pump				
Series	5 1.5 HP Permanent Magnet Motor / 55 cu.in.				
Motor Voltage	1 1 = 115 VAC Single Phase 2 = 230 VAC Single Phase				
Valve Function	<table border="0"> <tr> <td>3</td> <td>0 = Dump 1 = 2 Way Dump 2 = 2 Way Manual</td> <td>3 = 3 Way Manual 4 = 4 Way Manual 5 = 2 Way Solenoid</td> <td>6 = 3 Way Solenoid 7 = 4 Way Solenoid</td> </tr> </table>	3	0 = Dump 1 = 2 Way Dump 2 = 2 Way Manual	3 = 3 Way Manual 4 = 4 Way Manual 5 = 2 Way Solenoid	6 = 3 Way Solenoid 7 = 4 Way Solenoid
3	0 = Dump 1 = 2 Way Dump 2 = 2 Way Manual	3 = 3 Way Manual 4 = 4 Way Manual 5 = 2 Way Solenoid	6 = 3 Way Solenoid 7 = 4 Way Solenoid		
Reservoir Size	<table border="0"> <tr> <td>2</td> <td>2 = 1.5 Gallons Usable Oil 3 = 2.5 Gallons Usable Oil</td> <td>5 = 5 Gallons Usable Oil 6 = 10 Gallons Usable Oil</td> <td>7 = 20 Gallons Usable Oil</td> </tr> </table>	2	2 = 1.5 Gallons Usable Oil 3 = 2.5 Gallons Usable Oil	5 = 5 Gallons Usable Oil 6 = 10 Gallons Usable Oil	7 = 20 Gallons Usable Oil
2	2 = 1.5 Gallons Usable Oil 3 = 2.5 Gallons Usable Oil	5 = 5 Gallons Usable Oil 6 = 10 Gallons Usable Oil	7 = 20 Gallons Usable Oil		
Factory Installed Options*	<table border="0"> <tr> <td>G</td> <td>B = 3 Stage Pump C = Caster Wheel Kit F = Foot Switch (Motor)</td> <td>G = Pump Mounted Gauge H = Heat Exchanger L = Locking Style Manifold</td> <td>O = Oil Filter P = Pressure Switch R = Roll Cage S = Foot Switch (Valve)</td> </tr> </table>	G	B = 3 Stage Pump C = Caster Wheel Kit F = Foot Switch (Motor)	G = Pump Mounted Gauge H = Heat Exchanger L = Locking Style Manifold	O = Oil Filter P = Pressure Switch R = Roll Cage S = Foot Switch (Valve)
G	B = 3 Stage Pump C = Caster Wheel Kit F = Foot Switch (Motor)	G = Pump Mounted Gauge H = Heat Exchanger L = Locking Style Manifold	O = Oil Filter P = Pressure Switch R = Roll Cage S = Foot Switch (Valve)		

- * If pump model consists of more than 3 options, contact factory.
- * Gauge will not be protected by roll cage when a 5 gallon or larger reservoir is ordered.
- * Roll cage not available on 10 & 20 gallon reservoir.
- * Caster wheel kit not available on 5, 10 & 20 gallon reservoirs.
- * Oil filter not available on dump, 2 way dump & 2 way manual.
- * Motor pendant is standard on all models.

Power Pumps

POWER PUMPS

G6 Series - Electric

SIMPLEX

G6
Electric



G6335 Shown

Reservoir Capacity ▶ 5 - 40 gallons

Flow @ Rated Pressure ▶ 100 cu.in./min.

Maximum Pressure ▶ 10,000 psi

- ▶ Two-stage pump operation provides fast tool performance.
- ▶ Ideal for use with mid to large sized hydraulic cylinders or tools.
- ▶ Powered by a multi-voltage, 3 phase, 3 hp AC motor (3450 rpm); low startup voltage draws 9.5 amps (230v) at full load.
- ▶ Perfect fit for production and multi-cylinder lift systems.
- ▶ Quiet running, only (80dba).

Power Pumps



CYLINDERS - pages 7 - 29

A large selection of steel and aluminum cylinders to meet every need.



COUPLERS - pages 74 - 75

High flow quick disconnect couplers provide a quick change to a variety of pumps.



IN-LINE VALVES - page 72

Maximize control and safety with our in-line valves.



▲ Deluxe Starter Box is equipped on all models.

THINK SAFETY

Please refer to pages 4&5 for a complete list of safety tips and recommendations.



The G6 Series Electric pump can power a variety of Simplex tools while withstanding the daily wear and tear in this steel fabricating shop. ▼

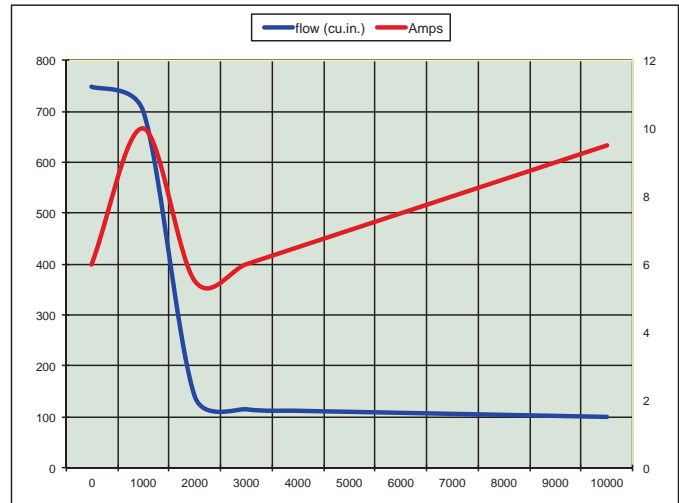

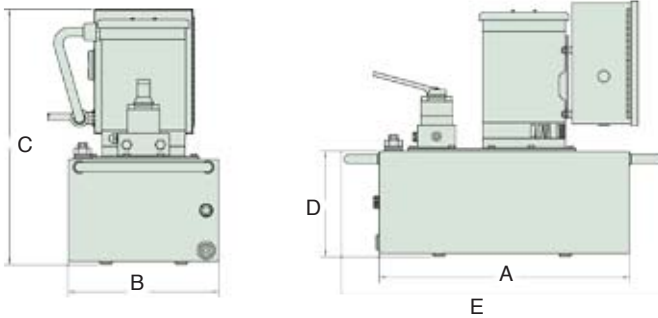

Reservoir (Gallons)	A	B	C	D	E
	(in)	(in)	(in)	(in)	(in)
5	19.62	11.75	20.52	8.46	25.10
10	19.62	11.75	24.76	12.71	25.10
20	23.50	19.60	24.51	12.46	28
40	36	24	24.7	12.25	41.5

Model	Pressure Rating (psi)		Output Flow (cu.in./min.)		Motor Spec.		Valve Type	Pendant Control	Usable Oil	Weight (lbs)
	1st Stage	2nd Stage	1st Stage	2nd Stage	(vac)	(amps)				
G6335	1,500	10,000	750	100	230	9.5	3W, 3P	----	5	162
G6336	1,500	10,000	750	100	230	9.5	3W, 3P	----	10	217
G6336L	1,500	10,000	750	100	230	9.5	3W, 3P (L)	----	10	218
G6365	1,500	10,000	750	100	230	9.5	3W, 3P	Solenoid	5	165
G6366	1,500	10,000	750	100	230	9.5	3W, 3P	Solenoid	10	220
G6366L	1,500	10,000	750	100	230	9.5	3W, 3P (L)	Solenoid	10	221
G6346	1,500	10,000	750	100	230	9.5	4W, 3P	----	10	210
G6347	1,500	10,000	750	100	230	9.5	4W, 3P	----	20	311
G6347L	1,500	10,000	750	100	230	9.5	4W, 3P (L)	----	20	312
G6375	1,500	10,000	750	100	230	9.5	4W, 3P	Solenoid	5	165
G6376	1,500	10,000	750	100	230	9.5	4W, 3P	Solenoid	10	220
G6376L	1,500	10,000	750	100	230	9.5	4W, 3P (L)	Solenoid	10	221

(L) = Lock Valve Manifold

- * For 230 VAC pump use "3" in the 3rd character of the model number. Motor specifications 2,2 kw 3 phase, 10 amps @ 230 VAC.
- * For 380 VAC pump use "4" in the 3rd character of the model number. Motor specifications 2,2 kw 3 phase, 5.8 amps @ 380 VAC.
- * For 460 VAC pump use "5" in the 3rd character of the model number. Motor specifications 2,2 kw 3 phase, 4.7 amps @ 460 VAC.
- * For 575 VAC pump use "6" in the 3rd character of the model number. Motor specifications 2,2 kw 3 phase, 3.8 amps @ 575 VAC.

Additional Pump Configurations

MODEL	SELECTIONS
Class	G = Power Pump
Series	6 = 3 HP / 3 Phase / 100 cu.in.
Motor Voltage	3 = 230 VAC, 3 Phase 4 = 380 VAC, 3 Phase 5 = 460 VAC, 3 Phase 6 = 575 VAC, 3 Phase
Valve Function	3 = 2 = 2 Way Manual 3 = 3 Way Manual 4 = 4 Way Manual 6 = 3 Way Solenoid 7 = 4 Way Solenoid
Reservoir Size	5 = 5 Gallons Usable Oil 6 = 10 Gallons Usable Oil 7 = 20 Gallons Usable Oil 8 = 40 Gallons Usable Oil
Factory Installed Options *	F = Foot Switch (Motor) G = Gauge (Integrated) H = Heat Exchanger L = Locking Style Manifold M = Motor Pendant O = Oil Filter P = Pressure Switch S = Foot Switch (Valve)

* If pump consists of more than 3 options, consult factory.
* Oil filter not available on 2 way manual.



G5733 Shown

Reservoir Capacity▶ 1.5 - 20 gallons

Flow @ Rated Pressure▶ 55 cu.in./min.

Maximum Pressure▶ 10,000 psi

- ▶ Powered by a rotary air vane, 3 hp motor (3,000 rpm).
- ▶ Equipped with a filter-lubricator assembly, air muffler and carry handlebar on all models.
- ▶ Precision designed valve offers reliability and secure load holding; external adjustable relief standard on all models.
- ▶ Ideal for use with mid sized hydraulic cylinders or tools.



CYLINDERS - pages 7 - 29

A large selection of steel and aluminum cylinders to meet every need.



COUPLERS - pages 74 - 75

High flow quick disconnect couplers provide a quick change to a variety of pumps.



GAUGES - page 77

Improve your system visibility and safety by adding an inline hydraulic gauge to your circuit.



SUC-O-MATIC VALVE

The 3 position / 3 way "Suc-O-Matic" valve draws hydraulic oil out of any single acting cylinder with full retraction regardless of weak springs or mounting.



THINK SAFETY

Please refer to pages 4&5 for a complete list of safety tips and recommendations.

The power and dependability of the G5 Air Power Pump is the perfect solution for any job where electric and gasoline powered tools are not suitable. ▼

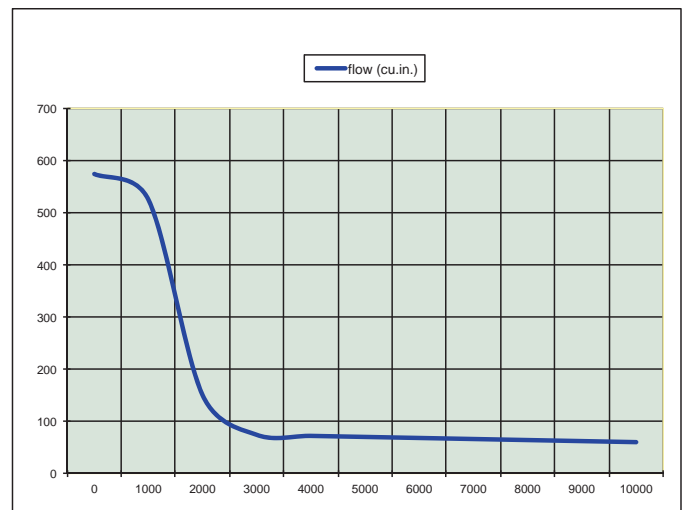
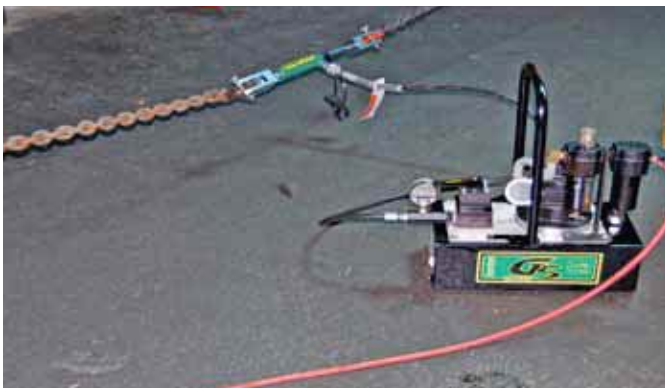

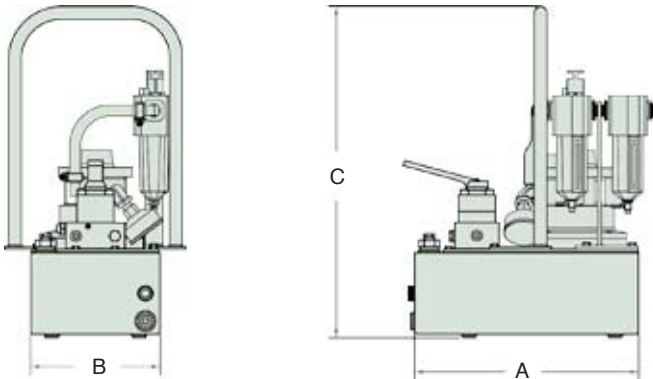

Reservoir (Gallons)	A	B	C
	(in)	(in)	(in)
1.5	15.13	8.75	22.34
2.5	17	9.75	22.34
5	25.10	11.75	20.52
10	25.10	11.75	24.77
20	28	19.62	26.69

Model	Pressure Rating (psi)		Output Flow (cu. in. / min.)		Motor Spec.		Valve Type	Pendant Control	Usable Oil	Weight (lbs)
	1st Stage	2nd Stage	1st Stage	2nd Stage	(psi)	(cfm)				
G5732	1,100	10,000	700	55	90	50	3W, 3P	-----	1.5	50
G5735	1,100	10,000	700	55	90	50	3W, 3P	-----	5	108
G5762	1,100	10,000	700	55	90	50	3W, 3P	Solenoid	1.5	52
G5765	1,100	10,000	700	55	90	50	3W, 3P	Solenoid	5	110
G5742	1,100	10,000	700	55	90	50	4W, 3P	-----	1.5	50
G5745	1,100	10,000	700	55	90	50	4W, 3P	-----	5	108
G5772	1,100	10,000	700	55	90	50	4W, 3P	Solenoid	1.5	52
G5775	1,100	10,000	700	55	90	50	4W, 3P	Solenoid	5	110

Additional Pump Configurations

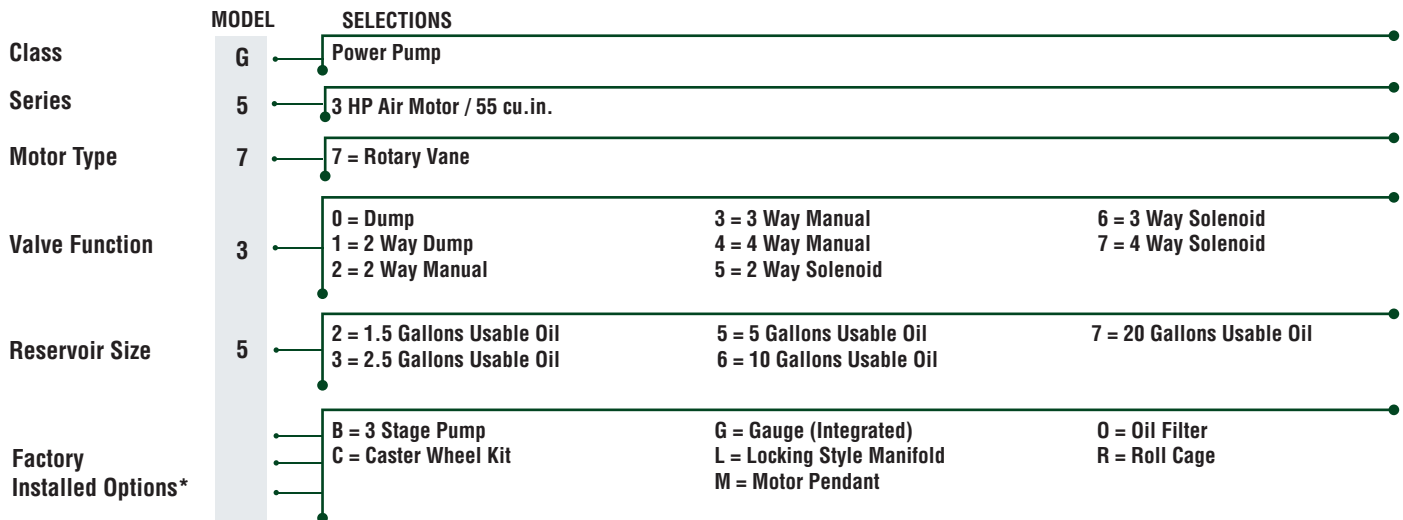

* If pump model consists of more than 3 options, contact factory.
 * Gauge will not be protected by roll cage when a 5 gallon or larger reservoir is ordered.
 * Roll cage not available on 10 & 20 gallon reservoir.
 * Caster wheel kit not available on 5, 10 & 20 gallon reservoirs.
 * Oil filter not available on dump, 2 way dump & 2 way manual.



G4833 Shown

Reservoir Capacity ▶ 1.5 - 20 gallons

Flow @ Rated Pressure ▶ 50 cu.in./min.

Maximum Pressure ▶ 10,000 psi

- ▶ Powered by a 127 c.c. Briggs & Stratton® gas motor.
- ▶ High performance two-stage pump provides higher cross-over pressure for faster cycle times and equipment operation; 50 cubic inches / minute @ 10,000 PSI.
- ▶ Reservoirs available in 1.5 - 20 gallons; welded steel design.
- ▶ Ideal for use with mid sized hydraulic cylinders or tools.



MANIFOLDS - page 73

The ideal solution in obtaining precise control when operating multiple cylinders.



COUPLERS - pages 74 - 75

High flow quick disconnect couplers provide a quick change to a variety of pumps.



GAUGES - page 77

Improve your system visibility and safety by adding an inline hydraulic gauge to your circuit.



SUC-O-MATIC VALVE

The 3 position / 3 way "Suc-O-Matic" valve draws hydraulic oil out of any single acting cylinder with full retraction regardless of weak springs or mounting.



THINK SAFETY

Please refer to pages 4&5 for a complete list of safety tips and recommendations.

The location to repair this dock foundation needed the versatility of the G4 gas power pump. ▼

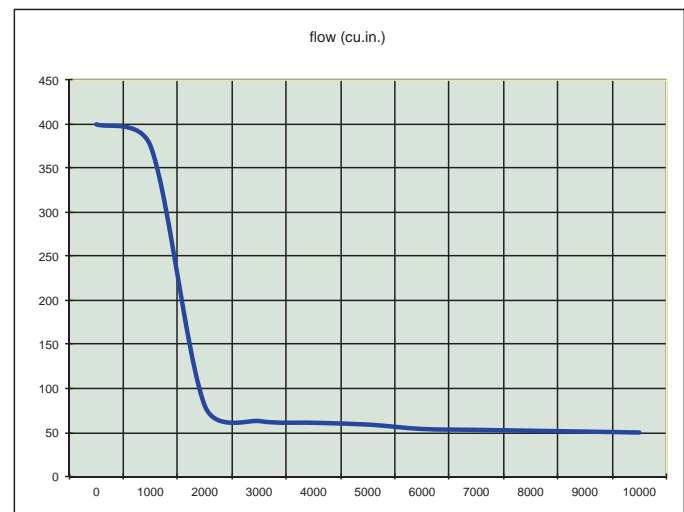

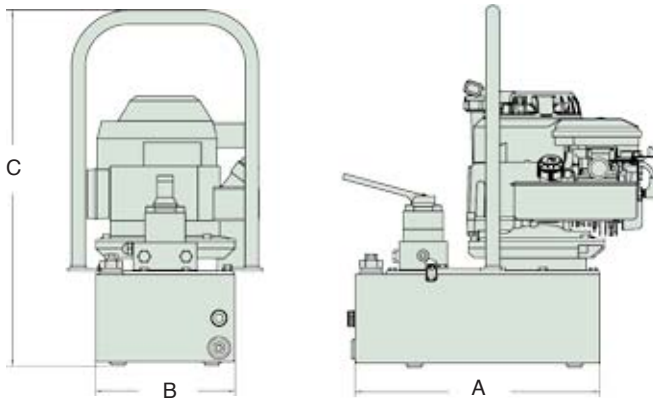

Reservoir (Gallons)	A	B	C
	(in)	(in)	(in)
1.5	15.13	8.75	22.34
2.5	17	9.75	22.34
5	25.10	11.75	19.54
10	25.10	11.75	23.97
20	28	19.60	22.84

Model	Pressure Rating (psi)		Output Flow (cu. in. / min.)		Motor B&S	Valve Type	Usable Oil	Weight (lbs)
	1st Stage	2nd Stage	1st Stage	2nd Stage				
<i>G4833</i>	1,100	10,000	400	50	127 c.c.	3W, 3P	2.5	53
<i>G4835</i>	1,100	10,000	400	50	127 c.c.	3W, 3P	5	108
<i>G4843</i>	1,100	10,000	400	50	127 c.c.	4W, 3P	2.5	53
<i>G4845</i>	1,100	10,000	400	50	127 c.c.	4W, 3P	5	108

Additional Pump Configurations

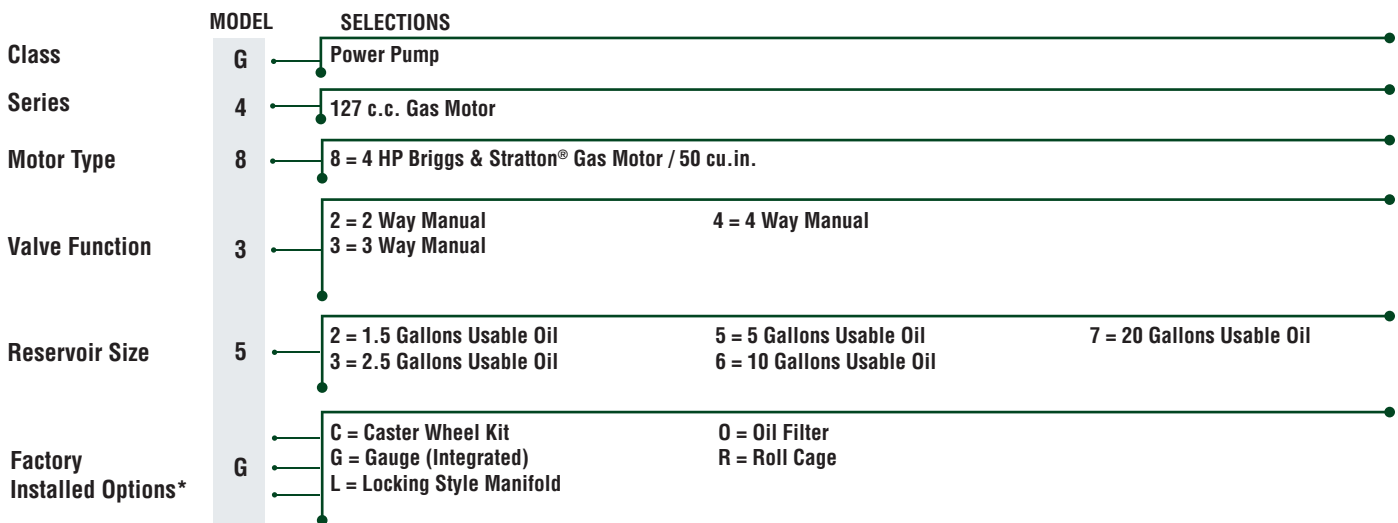

* If pump model consists of more than 3 options, contact factory.
 * Gauge will not be protected by roll cage when a 5 gallon or larger reservoir is ordered.
 * Roll cage not available on 10 & 20 gallon reservoir.
 * Caster wheel kit not available on 5, 10 & 20 gallon reservoirs.
 * Oil filter not available on dump, 2 way dump & 2 way manual.

POWER PUMPS

G6 Series - Gas

SIMPLEX

G6
Gas



G6843 Shown

Reservoir Capacity▶ 2.5 - 20 gallons
Flow @ Rated Pressure.....▶ 100 cu.in./min.
Maximum Pressure▶ 10,000 psi

- ▶ Powered by a 163 c.c. Honda® gas motor.
- ▶ High performance two-stage pump provides higher cross-over pressure for faster cycle times and equipment operation.
- ▶ Ideal for use with mid to large sized hydraulic cylinders or tools.
- ▶ Reservoirs available in 2.5 - 20 gallons; welded steel design.
- ▶ Precision designed valve offers reliability and secure load holding.

Power Pumps



MANIFOLDS - page 73

The ideal solution in obtaining precise control when operating multiple cylinders.



COUPLERS - pages 74 - 75

High flow quick disconnect couplers provide a quick change to a variety of pumps.



GAUGES - page 77

Improve your system visibility and safety by adding an inline hydraulic gauge to your circuit.



SUC-O-MATIC VALVE

The 3 position / 3 way "Suc-O-Matic" valve draws hydraulic oil out of any single acting cylinder with full retraction regardless of weak springs or mounting.



THINK SAFETY

Please refer to pages 4&5 for a complete list of safety tips and recommendations.

The G6 Series Gas pump can withstand the most rugged environments without ever compromising performance. ▼

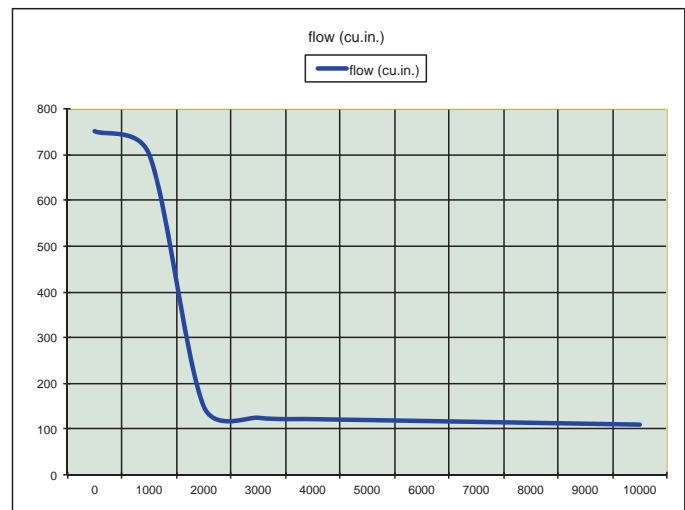

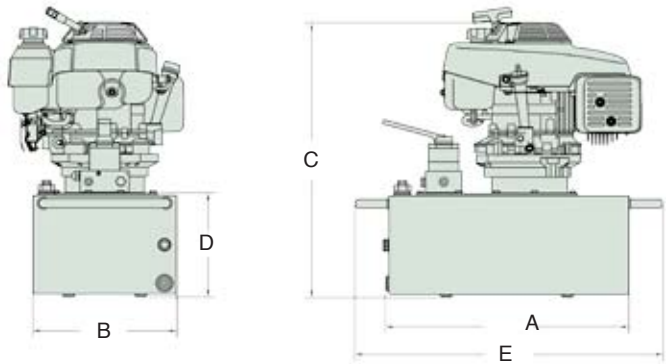

Reservoir (Gallons)	A	B	C	D	E
	(in)	(in)	(in)	(in)	(in)
2.5	17	9.75	19.86	5.71	----
5	19.60	11.75	22.36	8.46	25.10
10	19.60	11.75	26.61	12.71	25.10
20	23.50	19.60	26.36	12.46	28





28 x 22.68 x 18.75 Roll Cage Dimensions for 2.5 gallon.





Model	Pressure Rating (psi)		Output Flow (cu. in./ min.)		Motor Spec	Valve Type	Usable Oil	Weight (lbs)
	1st Stage	2nd Stage	1st Stage	2nd Stage				
G6833	1,200	10,000	750	100	163 c.c.	3W, 3P	2.5	68
G6835	1,200	10,000	750	100	163 c.c.	3W, 3P	5	123
G6843	1,200	10,000	750	100	163 c.c.	4W, 3P	2.5	68
G6845	1,200	10,000	750	100	163 c.c.	4W, 3P	5	123

Additional Pump Configurations

	MODEL	SELECTIONS
Class	G	Power Pump
Series	6	163 c.c. Gas Motor
Motor Type	8	8 = Honda Gas Motor / 100 cu. in.
Valve Function	3	2 = 2 Way Manual 3 = 3 Way Manual 4 = 4 Way Manual
Reservoir Size	5	3 = 2.5 Gallons Usable Oil 5 = 5 Gallons Usable Oil 6 = 10 Gallons Usable Oil 7 = 20 Gallons Usable Oil
Factory Installed Options *	C	B = 3 Stage Pump C = Caster Wheel Kit (2.5 gal. only) G = Gauge (Integrated) L = Locking Style Manifold O = Oil Filter

* For reservoirs over 20 gallon capacity, please contact factory.
 * If pump model consists of more than 3 options, contact factory.
 * Oil filter not available with 2 way manual.

	<p>Order # G07-3M, G07-3S G07-4M, G07-4S</p> <p>3M = 3 Way Manual 4M = 4 Way Manual 3S = 3 Way Solenoid 4S = 4 Way Solenoid</p> <p>Monitor Pressure In The System By Incorporating An Integrated Pressure Gauge.</p>	<p>Integrated Pressure Gauge Kit</p> <ul style="list-style-type: none"> * Shcs .38-16 X 2.54 Gauge Shroud Mounting2 * Gauge Bracket Manual1 * BHCS 10-24 X .50 316SS.....4 Manifold Assembly.....1 * Valve Handle Assembly.....1 Gauge Shroud Assembly.....1 Instruction Sheet GO7.....1 * Extra Components In Manual 3 Or 4 Way Gauge Kit *
	<p>Order # G02</p> <p>Hands free pump control can be achieved with the 15 ft. cord Foot Switch.</p>	<p>Foot Switch Kit</p> <ul style="list-style-type: none"> Foot Switch 1 18-3 Power Cord 15 Foot Cord Spade Terminal3 Instruction Sheet GO2..... 1
	<p>Order # G03</p> <p>Protect your G Series pump from jobsite mishaps with a lightweight industrial grade Roll Cage.</p>	<p>Roll Cage Kit</p> <ul style="list-style-type: none"> .25" Fender Washer4 HHCS .25 - 20 X .75 W/Nylon S.S4 Roll Cage1 Instruction Sheet GO3.....1
	<p>Order # G04 - 115 (FOR 115 VOLT Order # G04 - 230 (FOR 230 VOLT)</p> <p>Avoid pump overheating and costly repairs from long work periods with a coil induction Heat Exchanger.</p>	<p>Heat Exchanger Kit - 115 Volt / 230 Volt</p> <ul style="list-style-type: none"> Heat Exchanger Assembly G5 115V1 Bulkhead Elbow .38" Flare Tube2 Swivel Fitting1 Elbow .25" NPT To .38" Flare Tube1 Tube Heat Exchanger Pump To Cover Plate1 Tube Heat Exchanger Cover Plate To Tank1 Standoff Heat Exchanger4 BHCS .25-20 X 3/84 Hex Nut .25-20 Plated4 O-Ring .44 X .622 Ring Terminal .25"1 Cover Plate Standard.....1 Cover Plate Torque Wrench1 Instruction Sheet GO4.....1

	<p>Order # G05</p> <p>Protect your system from unwanted contaminants with an easy to install External Filter Kit.</p>	<p>External Filter Kit</p> <p>Filter Block W/ Relief Assembly1 Roll Pin .13 X .38 Lg1 SHCS .38-16 X 5.251 SHCS .38-16 X 6.254 Instruction Sheet GO51</p>
	<p>Order # G01</p> <p>Provide a safe distance from large loads with a handy 15 ft. heavy duty Pendant Control Kit.</p>	<p>Pendant Motor Control Kit</p> <p>Pendant Assembly1 Membrane Switch Label3 Decal Pendant Instruction1 Simplex Decal1 Instruction Sheet GO11</p>
	<p>Order # G06</p> <p>Give your G Series pump mobility with heavy duty Swivel Casters for easier movement on tough terrain.</p>	<p>Caster Kit</p> <p>Caster Strip2 Swivel Caster4 Acorn Nut .38 - 16 Plated4 FHCS .25 - 20 X .75 Length4 Instruction Sheet GO61 * Mounts Only To A: 1 - 1.5 - 2.5</p>
	<p>Order # WMT4</p> <p>Run Up To 4 Different Tools To Add Versatility To Your G Series Pump With A Multiport Adapter Kit.</p> <p><u>For Torque Wrench Pumps Only.</u></p>	<p>Multi-Port Adapter Kit</p> <p>Multi-Port Adapter Block1 Valve Adapter Multiport Assembly2 Pipe Plug .13" Flush W/ Coating4 SHCS .25 - 20 X 2" Length2 Hex Pipe Plug .25" W/ Coating1 Instruction Sheet WMT41</p>

POWER PUMPS

Compact Foot Pumps - Air Over Hydraulic

SIMPLEX

GA9

Air over Hydraulic



Air Foot Pump Family Shown

Usable Oil Capacity▶ 90 - 460 cu.in.

Weight▶ 18.5 - 41 lbs.

Maximum Pressure▶ 10,000 psi

- ▶ 3 position non-slip, diamond grip treadle for safe advance, hold & retract operation.
- ▶ Quiet operation - 85 dba @ 10,000 psi for in-house production.
- ▶ Rugged all metal construction.
- ▶ High quality rubber gasket seals.
- ▶ Integrated non-spill vent / oil level indicator.

Power Pumps



DETENT CLIP

Pedal can be used to reduce operator strain by locking in the release position.



NON-SKID FEET

Four mountable non-skid rubber feet can be used to make your pump stationary.



FOOT PEDAL

A non-slip diamond plate texture gives the user safe and controlled foot pivoting action.

GA9 Series Cutaway View



SERVICE KITS

A large selection of serviceable part kits are offered to reduce operating costs and down time.

Engineers selected the Simplex air pump when reliable 10,000 psi power was needed to run this production line fixture. ▼

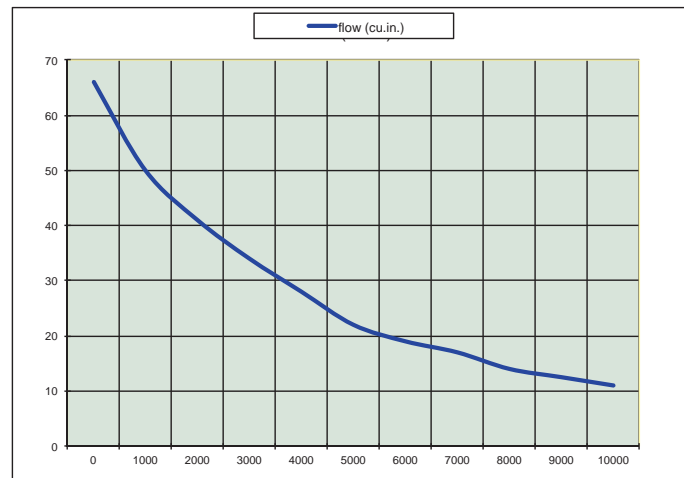



GA9 - 90 cu. in. Reservoir

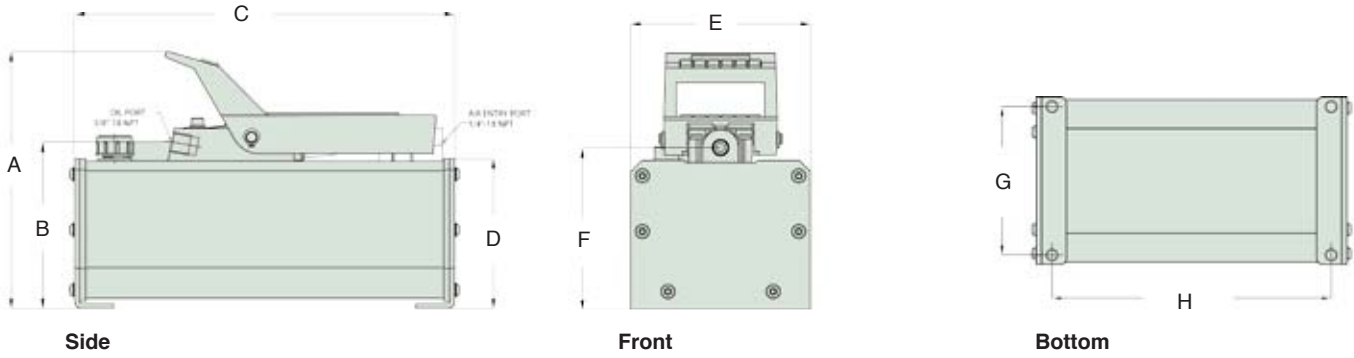

GA9 - 230 / 460 cu. in. Reservoir

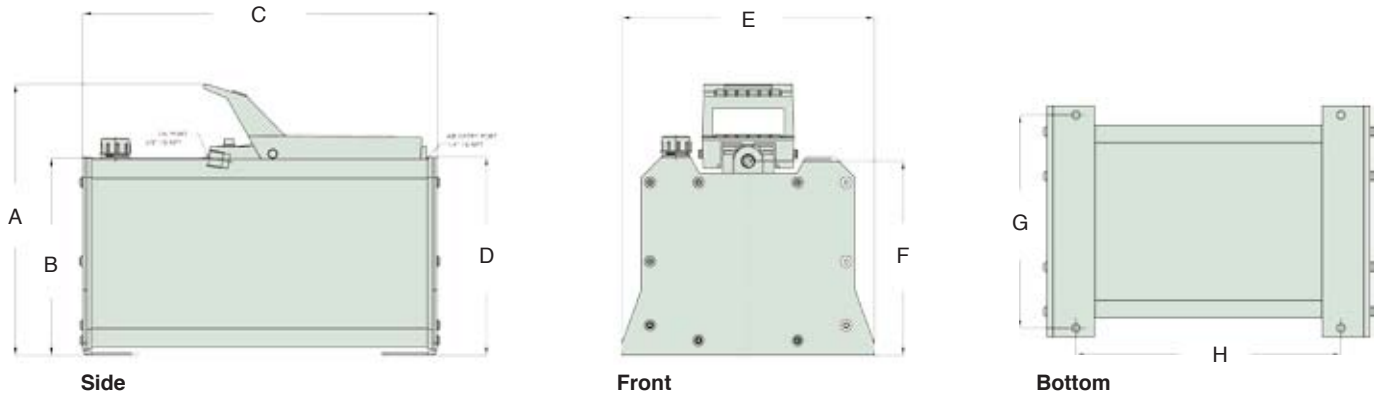

Model	Tool Type	Control	Usable Oil Capacity (cu. in.)	Oil Flow @ 0 psi (cu. in.)	Oil Flow @ 10,000 psi (cu. in.)	Operating Air Pressure Range (psi)	Weight (lbs)	Reservoir Sizes (in)						Mounting Holes (in)	
								A	B	C	D	E	F	G	H
GA90	S/A	Foot Pedal	90	68	11	60 - 150	18.5	8.38	5.32	10.69	4.81	5.81	5.25	5.01	9.27
GA9230	S/A	Foot Pedal	230	68	11	60 - 150	32.6	11.88	7.94	10.63	7.94	9.84	7.88	9.05	11.29
GA9460	S/A	Foot Pedal	460	68	11	60 - 150	41	11.88	7.94	14.06	7.94	9.84	7.88	9.05	11.29
GA90R	S/A	Pendant	90	68	8	60 - 150	23.5	8.38	5.32	10.69	4.81	5.81	5.25	5.01	9.27
GA9230R	S/A	Pendant	230	68	8	60 - 150	37.6	11.88	7.94	10.63	7.94	9.84	7.88	9.05	11.29
GA9230D	D/A	Valve	230	68	11	60 - 150	31.6	11.88	7.94	10.63	7.94	9.84	7.88	9.05	11.29
GA9460D	D/A	Valve	460	68	11	60 - 150	41	11.88	7.94	14.06	7.94	9.84	7.88	9.05	11.29

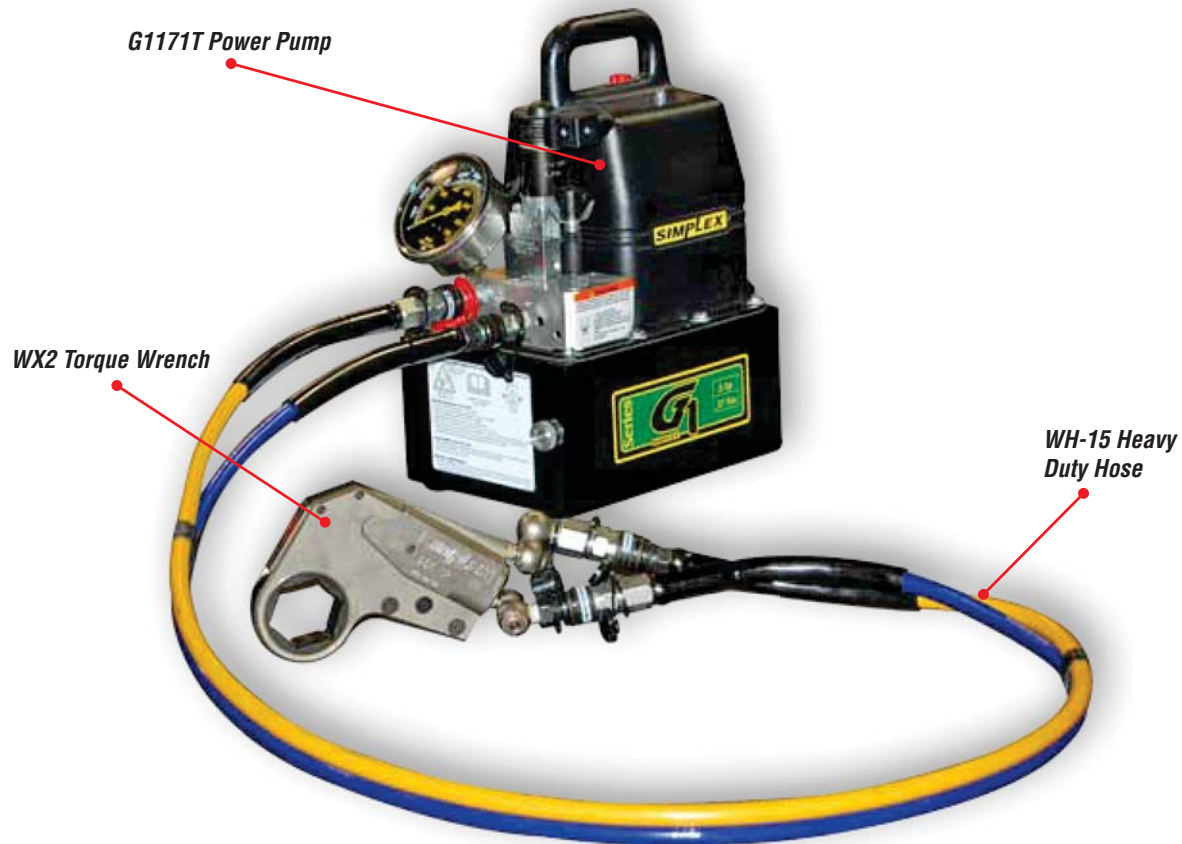

Standard Bolting Model Shown

PRODUCT LINE OVERVIEW

► Bolting Features

Simplex offers a wide variety of hydraulic torque wrenches available in square drive design or low clearance wrenches. These tools are the most versatile in the business. Optional attachments and accessories are available to complement both style wrenches.

► WT-Series Square Drive Wrenches

The Simplex square drive wrench combines strength and simplicity to handle the toughest bolting jobs. Simplex square drive wrenches come with a push through drive in the .75", 1" and 1.5" models, eliminating pulling the drive out of a wrench to change drive direction. The WT-Series wrenches can react off the wrench body for close quarter applications. Several optional accessories are available.

► WX-Series Low Clearance Wrenches

Simplex Low Clearance wrenches are the flattest wrenches available, utilizing a patented low height piston. The Simplex WX series wrenches fit in places competitive wrenches cannot. The low clearance wrenches have a wide choice of links available in .06" increments. Metric sizes are also available. Several optional accessories are available such as hex reducers, hex to square drive adaptors and different reaction arms.

► Bolting Accessories

Simplex torque wrench pumps are available in both electric and air power. Simplex electric pumps are smooth running, continuous duty pumps with permanent magnet motors that will start and run under full load on as little as 60VAC. An integrated auto shut-off switch, along with a steel reservoir, keeps the oil and pump cool and helps prevent pump breakdown. Hoses are twin style with a 4:1 safety factor and the pump mounted gauge reads out in 100 psi increments.

BOLTING PRODUCTS

Proper Size & Selection

SIMPLEX

G1 Bolting Pump

19 cu.in. / min. @ 10,000 psi



*An intermittent .5 hp pump that is best suited to power small size torque wrenches. It's easy to transport and very lightweight.
Starting weight @ 36 lbs.*

G5 Bolting Pump

55 cu.in. / min. @ 10,000 psi



*A continuous duty 1.5 hp pump that is best suited for medium to large torque wrenches.
Starting weight @ 75 lbs.*

G3 Bolting Pump

46 cu.in. / min. @ 10,000 psi



*A continuous duty 1.13 hp pump that is best suited to power small to medium torque wrenches. Ideal for systems that require high performance, with lightweight portability.
Starting weight @ 57 lbs.*

G5 Bolting Pump - Air

55 cu.in. / min. @ 10,000 psi



*A continuous duty air pump that is best suited for medium to large size torque wrenches. The high flow rate runs multiple tools efficiently.
Starting weight @ 75 lbs.*

Bolting Wrenches

Square Drive & Low Clearance Wrenches



Simplex offers a wide variety of hydraulic wrenches available in lightweight square drive design or the flat low clearance design. Optional attachments and accessories are available for both style wrenches to simplify your task.

Hoses & Manifolds



A complete set of high performance, high pressure hose styles and sizes are available to fit any application, along with an 8 port manifold allowing the user the ability to use up to four tools at once.

Selecting The Bolting System



Selecting The Proper Pump

All SIMPLEX bolting pumps are configured specifically for bolting applications. Each “turnkey” power pump includes polarized couplers, external adjustable relief valve, pump mounted gauge and optional multi-port manifold for multiple tools. When selecting a power pump, consider the power requirements; air, 115 vac or 230 vac, 2nd stage hydraulic flow, pump operating / interval time, number of tools being operated and weight. Refer to the internal pages for details.



Selecting The Proper Hose

All SIMPLEX hoses are thermo-plastic, banded together, color coded and polarized for plug and play operation. Lengths are available in 15, 20 and 40 feet. Each bolting hose has a 4:1 safety factor that provides you with the flexibility to meet any project requirement.



Selecting The Proper Tool

A hydraulic torque wrench is a tool used to precisely set the hydraulic torque of a fastener such as a nut or bolt. Our hydraulic torque wrenches are available in a square drive and low profile design. Consider the amount of torque, footprint requirements and reaction area when selecting your wrench.

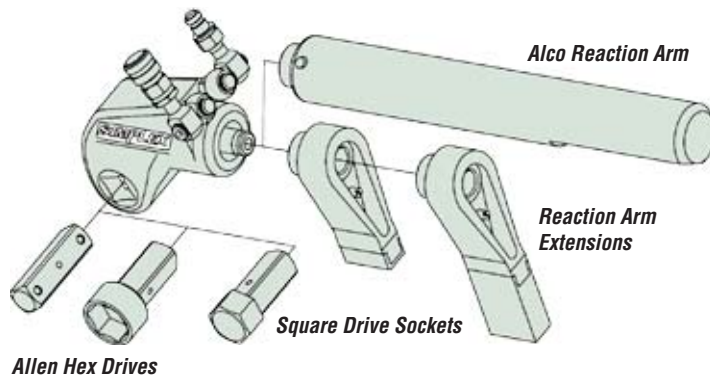

WT Series Square Drive Wrench

Simplex square drive wrenches come with a push through drive in the .75", 1" and 1.5" models, eliminating pulling the drive out of a wrench to change drive direction. The WT Series wrenches can react off the wrench body for close quarter applications. Several optional accessories such as Alco Reaction Arms, extensions and sockets are available for your specific needs.

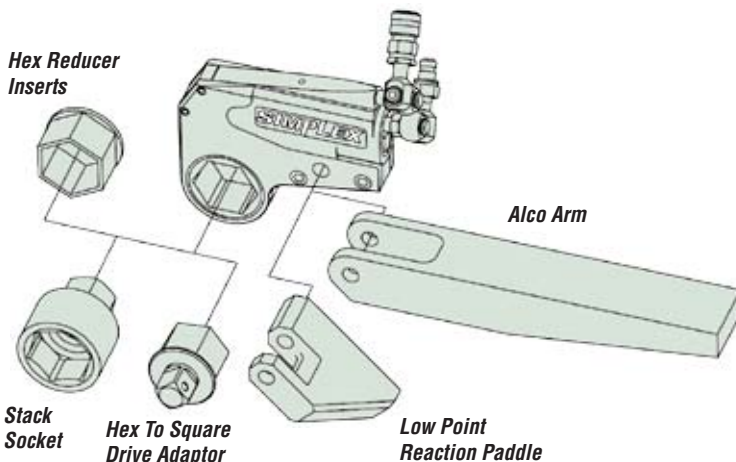

WX Series Low Clearance Wrench

Simplex low clearance wrenches fit in places that competitive style wrenches cannot. The low clearance wrenches have a wide choice of links available in .06" increments. Several optional accessories are available such as hex reducers, hex to square drive adaptors and different reaction arms.

BOLTING PUMPS

G1 Series - Electric

SIMPLEX



G1171T Shown

Reservoir Capacity▶ 1 gallon
 Weight▶ 36 lbs.
 Maximum Pressure▶ 10,000 psi

- ▶ Light weight bolting pump equipped with an integrated gauge, adjustable relief and 15' remote power controlled pendant.
- ▶ Powered by a 115V - 60Hz, .5 hp universal motor (14,640 rpm).
- ▶ Low startup voltage, draws 10 amps at full load (230V model available).
- ▶ Two-speed pump operation provides fast tool performance.

Bolting Products



TORQUE WRENCHES - pages 88 - 91
 Torque wrenches available in lightweight square drive, or low clearance wrenches.



THINK SAFETY
 Please refer to pages 4&5 for a complete list of safety tips and recommendations.



TORQUE HOSES - page 89
 Heavy duty, thermo-plastic torque wrench hoses to meet your requirements.

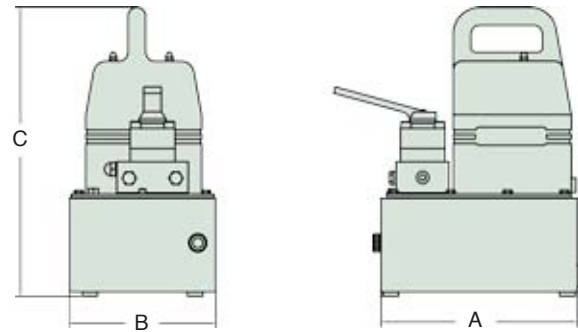

The G1 bolting pump along with a WX series low clearance torque wrench was used to tighten the footing of this support tower. ▼



Reservoir (Gallons)	A	B	C
	(in)	(in)	(in)
1 (metal)	11	8.17	16.17

* For 230 VAC pump use "2" in the 3rd character of the model number. Motor specifications 0,37 kw single phase, 5 amps @ 230 VAC.

Model	Pressure Rating (psi)		Output Flow (cu.in./min.)		Motor Spec.		Valve Type	Pendant Control	Usable Oil (Gallon)	Weight (lbs)
	1st Stage	2nd Stage	1st Stage	2nd Stage	(vac)	(amps)				
G1171T	400	10,000	250	19	115	10	4W, 2P	Motor / Solenoid	1	36



G3171T Shown

Reservoir Capacity▶ 1 - 2.5 gallons

Weight▶ 57 - 69 lbs.

Maximum Pressure▶ 10,000 psi

- ▶ Heavy Duty bolting pump is ideal for use with small to mid-sized torque wrenches.
- ▶ High performance two-stage pump provides higher cross-over pressure for faster cycle times and tool operation; 46 cubic inches / minute @ 10,000 PSI.
- ▶ Powered by a 115V - 60Hz, 1-1/8 hp universal motor.

TORQUE HOSES - page 89
Heavy duty, thermo-plastic torque wrench hoses to meet your requirements.

TORQUE WRENCHES - pages 88 - 91
Torque wrenches available in lightweight square drive, or low clearance wrenches.

G3 Bolting Pump Factory Installed Options

For ordering, add option letter to end of the model number.



The ease of operation and mobility from the G3 bolting pump was needed to repair the massive chuck on this CNC machine.▼

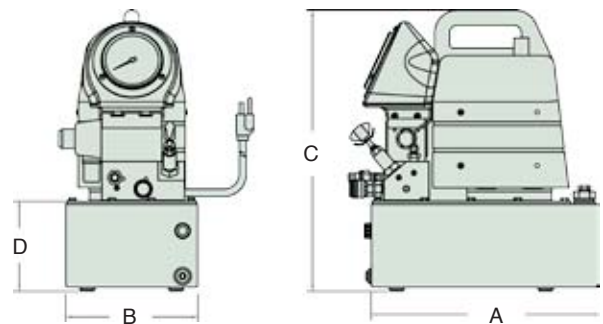

Reservoir (Gallons)	A	B	C	D
	(in)	(in)	(in)	(in)
1.5	15.13	8.75	19	5.96
2.5	17	9.75	19	5.96

* For 230 VAC pump use "2" in the 3rd character of the model number. Motor specifications 0,8 kw single phase, 10 amps @ 230 VAC.

Model	Pressure Rating (psi) Stages		Output Flow (cu.in./min.) Stages		Motor Spec.		Valve Type	Pendant Control	Usable Oil (Gallons)	Weight (lbs)
	1st	2nd	1st	2nd	(vac)	(amps)				
G3171T	1,100	10,000	525	46	115	16	4W, 2P	Motor / Solenoid	1	57
G3172T	1,100	10,000	525	46	115	16	4W, 2P	Motor / Solenoid	1.5	62
G3173T	1,100	10,000	525	46	115	16	4W, 2P	Motor / Solenoid	2.5	69

BOLTING PUMPS

G5 Series - Electric

SIMPLEX



G5172T Shown

Reservoir Capacity► 1.5 - 2.5 gallons

Weight► 75 - 85 lbs.

Maximum Pressure► 10,000 psi

- Heavy Duty bolting pump configuration is ideal for use with mid to large sized torque wrenches.
- Powered by a 115V - 60Hz, 1-1/2 hp permanent magnet motor (3,000 rpm); low startup voltage, draws 18 amps at full load (230V models available).
- High performance two-stage pump provides higher cross-over pressure for faster cycle times and tool operation.

Bolting Products



TORQUE WRENCHES - pages 88 - 91

Torque wrenches available in lightweight square drive, or low clearance wrenches.



THINK SAFETY

Please refer to pages 4&5 for a complete list of safety tips and recommendations.

G5 Bolting Pump Factory Installed Options

For ordering, add option letter to end of the model number.



Multi-Port Manifold



Caster Kit

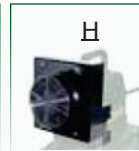

Heat Exchanger

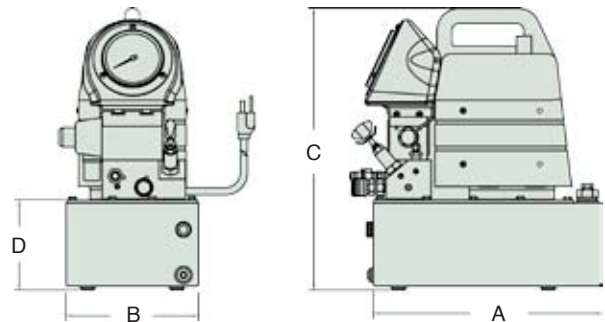

Reservoir (Gallons)	A	B	C	D
	(in)	(in)	(in)	(in)
1.5	15.13	8.75	19	5.96
2.5	17	9.75	19	5.96

Larger capacities available upon request.

The G5 pump had the flexibility and power to be instrumental in the construction of the blade section on this wind turbine. ▼



* For 230 VAC pump use "2" in the 3rd character of the model number. Motor specifications 1,1 kw single phase, 10 amps @ 230 VAC.

Model	Pressure Rating (psi) Stages		Output Flow (cu.in./min.) Stages		Motor Spec.		Valve Type	Pendant Control	Usable Oil (Gallons)	Weight (lbs)
	1st	2nd	1st	2nd	(vac)	(amps)				
G5172T	1,200	10,000	500	55	115	18	4W, 2P	Motor / Solenoid	1.5	75
G5173T	1,200	10,000	500	55	115	18	4W, 2P	Motor / Solenoid	2.5	85



G5772T Shown

Reservoir Capacity▶ 1.5 - 2.5 gallons
 Weight▶ 75 - 85 lbs.
 Maximum Pressure▶ 10,000 psi

- ▶ Powered by a rotary air vane, 3 hp motor (3,000 rpm).
- ▶ Equipped with a filter-lubricator assembly, air muffler, adjustable relief and 12' remote controlled pendant on all models.
- ▶ High performance two-stage pump provides higher cross-over pressure for faster cycle times and tool operation; 55 cubic inches / minute @ 10,000 PSI.



TORQUE HOSES - page 89

Heavy duty, thermo-plastic torque wrench hoses to meet your requirements.



TORQUE WRENCHES - pages 88 - 91

Torque wrenches available in lightweight square drive, or low clearance wrenches.

G5 Air Bolting Pump Factory Installed Options

For ordering, add option letter to end of the model number.



Multi-Port Manifold

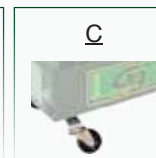

Caster Kit



Roll Cage

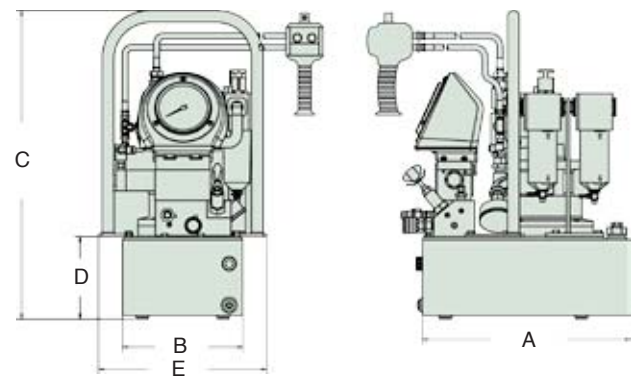

Reservoir (Gallons)	A	B	C	D	E
	(in)	(in)	(in)	(in)	(in)
1.5	15.13	8.75	22.34	5.96	12.24
2.5	17	9.75	22.34	5.96	13.24

Larger capacities available upon request.

A Simplex G5 Air pump is used with a WT-2 to remove the shroud on this steel cutter.▼



Model	Pressure Rating (psi) Stages		Output Flow (cu.in./min.) Stages		Motor Spec.		Valve Type	Pendant Control	Usable Oil (Gallons)	Weight (lbs)
	1st	2nd	1st	2nd	(psi)	(cfm)				
G5772T	1,200	10,000	700	55	90	50	4W, 2P	Motor / Solenoid	1.5	75
G5773T	1,200	10,000	700	55	90	50	4W, 2P	Motor / Solenoid	2.5	85

TORQUE WRENCHES

WT Series - Square Drive

SIMPLEX



WT2, WT3 & WT5 Shown

Maximum Torque @ 10,000 psi▶ 27,200 ft. lbs.

Square Drive Range▶ .75 - 2.5 in.

Maximum Pressure▶ 10,000 psi

- ▶ Hardened alloy square drive provides long life.
- ▶ No reaction pawl eliminates tool lockup.
- ▶ 27 degree stroke for high performance & speed.
- ▶ Push through square drive switches from tighten to loosen instantly.
- ▶ No leak couplers that swivel on double axis for ease of operation.
- ▶ Anti-Backlash mechanism prevents tool from back-driving.

TORQUE HOSES - page 89



Heavy duty, thermo-plastic torque wrench hoses to meet your requirements.

THINK SAFETY



Please refer to pages 4&5 for a complete list of safety tips and recommendations.

BOLTING PUMPS - pages 81-87



Torque wrench pumps are available in both electric and air power.

Lightweight, easy to use and reliable - The WT-5 torque wrench is used to certify flange assemblies in this fabricating shop.▼

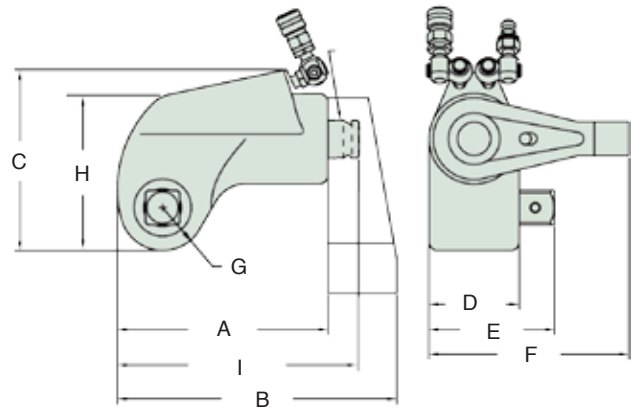

Model	A	B	C	D	E	F	G	H	I	Wgt. (lbs.)	Output (ft. lbs.)	Square Drive (in)	Available Socket Size (in)	Available Socket Size (mm)
	Length (in)	Length (in)	Height (in)	Width (in)	Width (in)	Width (in)	Radius (in)	Height (in)	Length (in)					
WT-2	4.68	6.10	4.20	2	2.76	4.42	.98	3.42	5.32	3.9	1,270	.75	.5 - 2.38	13 - 60
WT-3	6.10	8.10	5.30	2.62	3.68	5.81	1.30	4.54	6.68	9	3,330	1	.75 - 4.5	19 - 114
WT-5	8	10.74	6.99	3.61	5.06	7.98	1.70	6.05	9.48	19	7,170	1.5	1.31 - 5.38	33 - 137
WT-10	9.21	12.21	7.79	3.93	5.43	8.72	1.95	6.70	10.36	29	11,010	1.5	1.31 - 5.38	33 - 137
WT-27	12.29	16.29	10.19	5.26	7.73	11.63	2.43	8.82	13.87	70	27,200	2.5	1.62 - 9.25	41 - 235



Sockets For .75", 1" And 1.5" Drive Wrenches

Model Number for .75" Drive WT-2	Socket Size (in)	Model Number for 1" Drive WT-3	Socket Size (in)	Model Number for 1" Drive WT-3	Socket Size (in)	Model Number for 1" Drive WT-3	Socket Size (in)	Model Number for 1.5" Drive WT-5 & 10	Socket Size (in)	Model Number for 1.5" Drive WT-5 & 10	Socket Size (in)
WST1212	.75 x .75	WST1612	1 x .75	WST1633	1 x 2.06	WST1654	1 x 3.38	WST2422	1.5 x 1.38	WST2443	1.5 x 2.68
WST1213	.75 x .81	WST1613	1 x .81	WST1634	1 x 2.13	WST1655	1 x 3.44	WST2423	1.5 x 1.44	WST2444	1.5 x 2.75
WST1214	.75 x .87	WST1614	1 x .87	WST1635	1 x 2.19	WST1656	1 x 3.5	WST2424	1.5 x 1.5	WST2445	1.5 x 2.81
WST1215	.75 x .93	WST1615	1 x .93	WST1636	1 x 2.25	WST1657	1 x 3.56	WST2425	1.5 x 1.56	WST2446	1.5 x 2.87
WST1216	.75 x 1	WST1616	1 x 1	WST1637	1 x 2.31	WST1658	1 x 3.62	WST2426	1.5 x 1.62	WST2447	1.5 x 2.93
WST1217	.75 x 1.06	WST1617	1 x 1.06	WST1638	1 x 2.38	WST1659	1 x 3.68	WST2427	1.5 x 1.68	WST2448	1.5 x 3
WST1218	.75 x 1.13	WST1618	1 x 1.13	WST1639	1 x 2.44	WST1660	1 x 3.75	WST2428	1.5 x 1.75	WST2449	1.5 x 3.06
WST1219	.75 x 1.19	WST1619	1 x 1.19	WST1640	1 x 2.5	WST1661	1 x 3.81	WST2429	1.5 x 1.81	WST2450	1.5 x 3.13
WST1220	.75 x 1.25	WST1620	1 x 1.25	WST1641	1 x 2.56	WST1662	1 x 3.87	WST2430	1.5 x 1.87	WST2451	1.5 x 3.19
WST1221	.75 x 1.31	WST1621	1 x 1.31	WST1642	1 x 2.62	----	----	WST2431	1.5 x 1.93	WST2452	1.5 x 3.25
WST1222	.75 x 1.38	WST1622	1 x 1.38	WST1643	1 x 2.68	----	----	WST2432	1.5 x 2	WST2453	1.5 x 3.31
WST1223	.75 x 1.44	WST1623	1 x 1.44	WST1644	1 x 2.75	----	----	WST2433	1.5 x 2.06	WST2454	1.5 x 3.38
WST1224	.75 x 1.5	WST1624	1 x 1.5	WST1645	1 x 2.81	----	----	WST2434	1.5 x 2.13	WST2455	1.5 x 3.44
WST1225	.75 x 1.56	WST1625	1 x 1.56	WST1646	1 x 2.87	----	----	WST2435	1.5 x 2.19	WST2456	1.5 x 3.5
WST1226	.75 x 1.62	WST1626	1 x 1.62	WST1647	1 x 2.93	----	----	WST2436	1.5 x 2.25	WST2457	1.5 x 3.56
WST1227	.75 x 1.68	WST1627	1 x 1.68	WST1648	1 x 3	----	----	WST2437	1.5 x 2.31	WST2458	1.5 x 3.62
WST1228	.75 x 1.75	WST1628	1 x 1.75	WST1649	1 x 3.06	----	----	WST2438	1.5 x 2.38	WST2459	1.5 x 3.68
WST1229	.75 x 1.81	WST1629	1 x 1.81	WST1650	1 x 3.13	----	----	WST2439	1.5 x 2.44	WST2460	1.5 x 3.75
WST1230	.75 x 1.87	WST1630	1 x 1.87	WST1651	1 x 3.19	----	----	WST2440	1.5 x 2.5	----	----
WST1231	.75 x 1.93	WST1631	1 x 1.93	WST1652	1 x 3.25	----	----	WST2441	1.5 x 2.56	----	----
WST1232	.75 x 2	WST1632	1 x 2	WST1653	1 x 3.31	----	----	WST2442	1.5 x 2.62	----	----

Allen Hex Drive For WT Series Wrenches

Model	Wrench Model	Allen Hex Size (in)	Maximum Torque (ft./lbs)
WA-1208	WT-2	.5	395
WA-1210	WT-2	.62	740
WA-1212	WT-2	.75	1,270
WA-1214	WT-2	.87	1,270
WA-1216	WT-2	1	1,270
WA-1610	WT-3	.62	740
WA-1612	WT-3	.75	1,330
WA-1614	WT-3	.87	2,070
WA-1616	WT-3	1	3,100
WA-1618	WT-3	1.13	3,330
WA-1620	WT-3	1.25	3,330
WA-2414	WT-5	.87	2,070
WA-2416	WT-5	1	3,100
WA-2418	WT-5	1.13	4,355
WA-2420	WT-5	1.25	6,275
WA-2422	WT-5	1.38	7,170
WA-2424	WT-5	1.5	7,170
WA-2420-10	WT-10	1.25	6,275
WA-2422-10	WT-10	1.38	7,750
WA-2424-10	WT-10	1.5	10,500
WA-2426-10	WT-10	1.62	10,500
WA-2428-10	WT-10	1.75	10,500
WA-4024	WT-27	1.5	10,500
WA-4026	WT-27	1.62	13,280
WA-4028	WT-27	1.75	16,230
WA-4030	WT-27	1.87	27,200
WA-4032	WT-27	2	27,200
WA-4036	WT-27	2.25	27,200

Alco Reaction Arms



Model	Length (in)
WT2-ALCO	18
WT3-ALCO	22.25
WT5-ALCO	21
WT10-ALCO	23.5
WT27-ALCO	----

Reaction Arm Extensions

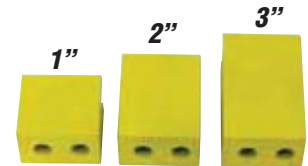

Model	Length (in)
WT3-EX1	1
WT3-EX2	2
WT3-EX3	3
WT5-EX1	1
WT5-EX2	2
WT5-EX3	3
WT10-EX1	1
WT10-EX2	2
WT10-EX3	3

Torque Wrench Hoses



Model	Length (ft)	Hose Type
WH-15	15	15' Blue & Yellow Duplex Hose w/ Quick Disconnect Couplers
WH-20	20	20' Blue & Yellow Duplex Hose w/ Quick Disconnect Couplers
WH-40	40	40' Blue & Yellow Duplex Hose w/ Quick Disconnect Couplers

TORQUE WRENCHES

WX Series - Low Clearance Wrenches

SIMPLEX



WX2, WX4 & WX8 Shown

Maximum Torque @ 10,000 psi▶ 35,600 ft. lbs.
 Tool Width▶ 1.25 - 3.24 in.
 Maximum Pressure▶ 10,000 psi

- ▶ Patented piston design for lower profile.
- ▶ Quick and easy interchangeable links requiring no tools.
- ▶ Accurate to within + / - 3%.
- ▶ Slim nose radius for tight spaces.
- ▶ Plated wrenches resist corrosion.

BOLTING PUMPS - pages 81-87

Torque wrench pumps are available in both electric and air power.



TORQUE HOSES - page 89

Heavy duty, thermo-plastic torque wrench hoses to meet your requirements.



OPTIONAL WX - SERIES ACCESSORIES

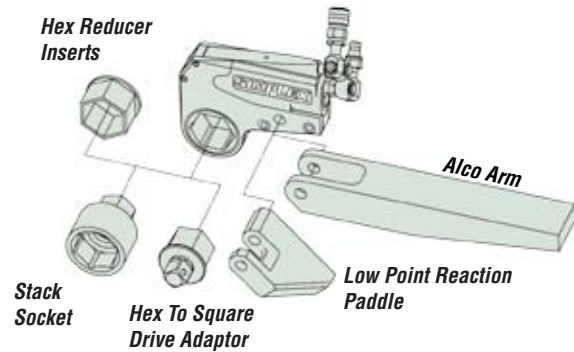

The WX-4 was the perfect solution for this spring tightening application. ▼

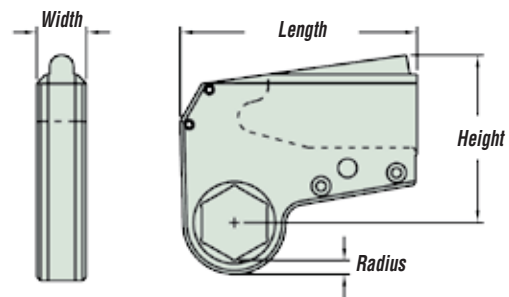

*Weight on Links will vary by size.

Model	Length (in)	Height (in)	Radius (in)	Max. Tool Width (in)	Output (ft. lbs.)	Weight (lbs.)
WX-2	5.67	4	.36	1.25	1,930	3.5
WX-4	7.80	5.60	.46	1.63	3,950	6
WX-8	9.80	7	.54	2.05	8,630	11.7
WX-16	12.93	7.58	.65	2.5	16,600	16
WX-32	15.30	10.90	.93	3.24	35,600	26

Available Link Sizes (in./mm)		*Weight (lbs.)
From	To	
.75" / 19mm	2.56" / 65mm	2.5 - 3.5
1" / 25mm	3.13" / 80mm	5.4 - 7.6
1.87" / 50mm	4" / 105mm	11.9 - 14.5
2.62" / 65mm	4.62" / 115mm	21 - 28
3.13" / 80mm	6.13" / 155mm	29 - 39.5

Wrench Handle



▲ Optional Wrench Handle - Order # WCH-1
Handles are available for the WX-8, WX-16 & WX-32. The handle can be screwed on either side of the wrench or on top of the wrench.

WX Drive Unit



▲ Select a WX drive unit that will give you the amount of torque you are looking for.

WXL Hex Link



▲ Couple your WX drive unit with the WXL hex link that you will need. See chart below for specific WXL link.

Accessories are available in imperial and metric sizes.

Model Number For WX-2 Links	Hex Size (in)	Model Number For WX-4 Links	Hex Size (in)	Model Number For WX-4 Links	Hex Size (in)	Model Number For WX-8 Links	Hex Size (in)	Model Number For WX-8 Links	Hex Size (in)	Model Number For WX-16 Links	Hex Size (in)	Model Number For WX-32 Links	Hex Size (in)	Model Number For WX-32 Links	Hex Size (in)
WXL2-12	.75	WXL4-16	1	WXL4-43	2.68	WXL8-30	1.87	WXL8-57	3.56	WXL16-42	2.62	WXL32-50	3.13	WXL32-87	5.44
WXL2-13	.81	WXL4-17	1.06	WXL4-44	2.75	WXL8-31	1.93	WXL8-58	3.62	WXL16-43	2.68	WXL32-51	3.19	WXL32-88	5.5
WXL2-14	.87	WXL4-18	1.13	WXL4-45	2.81	WXL8-32	2	WXL8-59	3.68	WXL16-44	2.75	WXL32-52	3.25	WXL32-89	5.56
WXL2-15	.93	WXL4-19	1.19	WXL4-46	2.87	WXL8-33	2.06	WXL8-60	3.75	WXL16-45	2.81	WXL32-53	3.31	WXL32-90	5.62
WXL2-16	1	WXL4-20	1.25	WXL4-47	2.93	WXL8-34	2.13	WXL8-61	3.81	WXL16-46	2.87	WXL32-54	3.38	WXL32-91	5.68
WXL2-17	1.06	WXL4-21	1.31	WXL4-48	3	WXL8-35	2.19	WXL8-62	3.87	WXL16-47	2.93	WXL32-55	3.44	WXL32-92	5.75
WXL2-18	1.13	WXL4-22	1.38	WXL4-49	3.06	WXL8-36	2.25	WXL8-63	3.93	WXL16-48	3	WXL32-56	3.5	WXL32-93	5.81
WXL2-19	1.19	WXL4-23	1.44	WXL4-50	3.13	WXL8-37	2.31	WXL8-64	4	WXL16-49	3.06	WXL32-57	3.56	WXL32-94	5.87
WXL2-20	1.25	WXL4-24	1.5	----	----	WXL8-38	2.38	----	----	WXL16-50	3.13	WXL32-58	3.62	WXL32-95	5.93
WXL2-21	1.31	WXL4-25	1.56	----	----	WXL8-39	2.44	----	----	WXL16-51	3.19	WXL32-59	3.68	WXL32-96	6
WXL2-22	1.38	WXL4-26	1.62	----	----	WXL8-40	2.5	----	----	WXL16-52	3.25	WXL32-60	3.75	WXL32-97	6.06
WXL2-23	1.44	WXL4-27	1.68	----	----	WXL8-41	2.56	----	----	WXL16-53	3.31	WXL32-61	3.81	WXL32-98	6.13
WXL2-24	1.5	WXL4-28	1.75	----	----	WXL8-42	2.62	----	----	WXL16-54	3.38	WXL32-62	3.87	----	----
WXL2-25	1.56	WXL4-29	1.81	----	----	WXL8-43	2.68	----	----	WXL16-55	3.44	WXL32-63	3.93	----	----
WXL2-26	1.62	WXL4-30	1.87	----	----	WXL8-44	2.75	----	----	WXL16-56	3.5	WXL32-64	4	----	----
WXL2-27	1.68	WXL4-31	1.93	----	----	WXL8-45	2.81	----	----	WXL16-58	3.62	WXL32-65	4.06	----	----
WXL2-28	1.75	WXL4-32	2	----	----	WXL8-46	2.87	----	----	WXL16-60	3.75	WXL32-66	4.13	----	----
WXL2-29	1.81	WXL4-33	2.06	----	----	WXL8-47	2.93	----	----	WXL16-62	3.87	WXL32-68	4.25	----	----
WXL2-30	1.87	WXL4-34	2.13	----	----	WXL8-48	3	----	----	WXL16-64	4	WXL32-70	4.38	----	----
WXL2-31	1.93	WXL4-35	2.19	----	----	WXL8-49	3.06	----	----	WXL16-66	4.13	WXL32-72	4.5	----	----
WXL2-32	2	WXL4-36	2.25	----	----	WXL8-50	3.13	----	----	WXL16-68	4.25	WXL32-74	4.62	----	----
WXL2-33	2.06	WXL4-37	2.31	----	----	WXL8-51	3.19	----	----	WXL16-70	4.38	WXL32-76	4.75	----	----
WXL2-34	2.13	WXL4-38	2.38	----	----	WXL8-52	3.25	----	----	WXL16-72	4.5	WXL32-78	4.87	----	----
WXL2-35	2.19	WXL4-39	2.44	----	----	WXL8-53	3.31	----	----	WXL16-74	4.62	WXL32-80	5	----	----
WXL2-36	2.25	WXL4-40	2.5	----	----	WXL8-54	3.38	----	----	----	----	WXL32-82	5.13	----	----
WXL2-37	2.31	WXL4-41	2.56	----	----	WXL8-55	3.44	----	----	----	----	WXL32-84	5.25	----	----
WXL2-38	2.38	WXL4-42	2.62	----	----	WXL8-56	3.5	----	----	----	----	WXL32-86	5.38	----	----

All Simplex Air Bags have a maximum working pressure of 116 PSI.

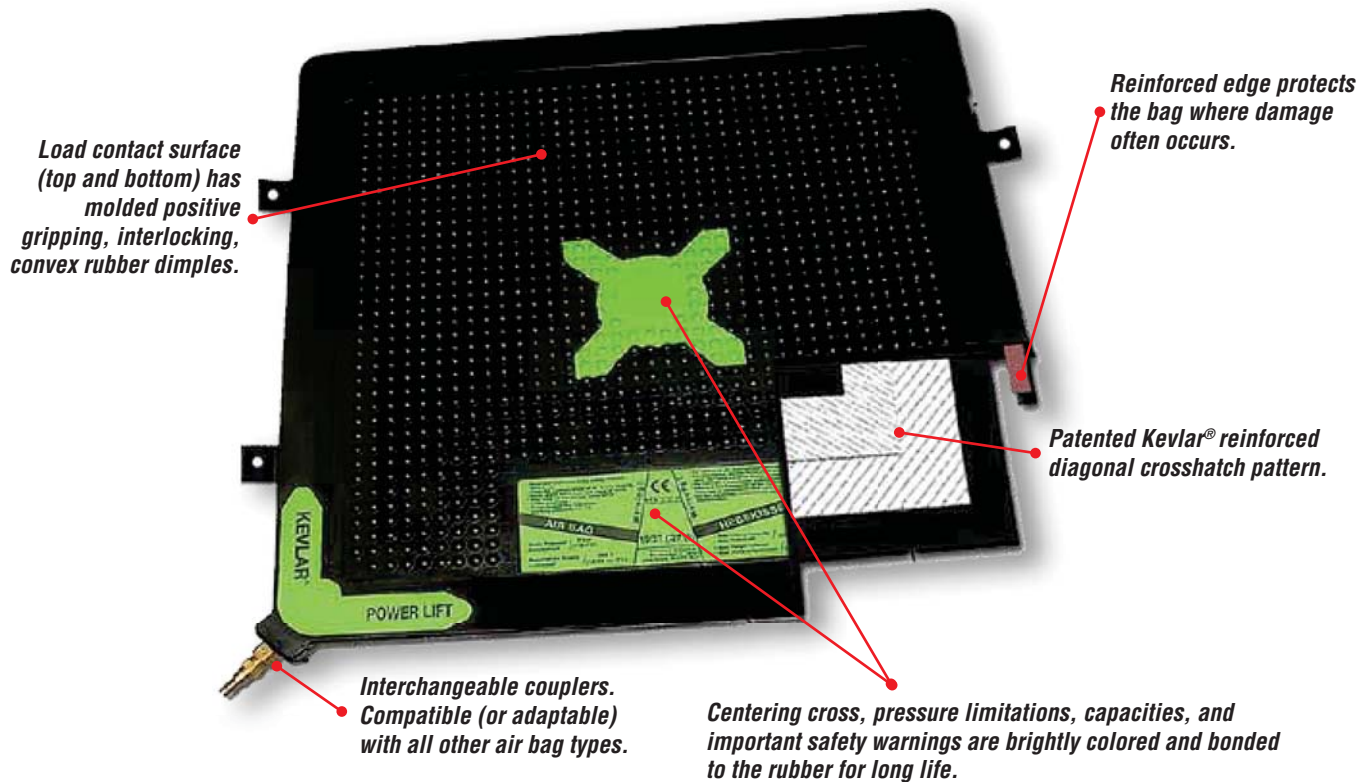

Heavy Duty Air Bag Shown

PRODUCT LINE OVERVIEW

► Something for Every Job

From the thinnest of air bags to the widest assortment of controls, Simplex heavy duty Air Bags provide a solution to the most unique and specialized application.

► General Maintenance

From factory maintenance to portable tool chests, Simplex Hand Jacks are the standard utility tools for all maintenance applications.

► Self Contained Mobile Force

From structural movers to plant maintenance crews, Simplex Toe Jacks offer high capacities in a broad range of lifting.

Hydraulic Hand Jacks

2 Through 100 Ton Hydraulic Hand Jacks

Simplex 2 through 100 ton capacity all purpose jacks are ideal for use in general industrial applications, and are used extensively in maintenance, construction and material handling. The versatility of the Simplex bottle jack has made it a favorite in shipyards, factories, oil fields, mines & general industries.



Hydraulic Toe Jacks

2 Through 10 Ton Hydraulic Toe Jacks

Simplex hydraulic toe jacks are the solution to all of your low clearance lifting problems. Choose from the widest variety of self contained toe jacks in the industry. Capacities range from 2 through 10 tons. The Simplex TJH2 is a 2 ton self-contained toe jack utilizing .62" minimum toe height and over 4" of travel.



Air Bags

1.1 Through 74.1 Tons Air Bags

Thin, powerful & light weight, Simplex Air Bags are the answer to the toughest industrial applications. Starting with a minimum height of 1.1", Simplex lifting bags offer high capacity for clearances too small for most conventional jacks. They are ideal for use in railroads, construction, mining, shipyards and industrial applications that require safe, reliable lifting, spreading, bending or pushing. Simplex air lifting bags are manufactured with neoprene & Kevlar reinforced construction and are safer, stronger and more reliable than other bags on the market.

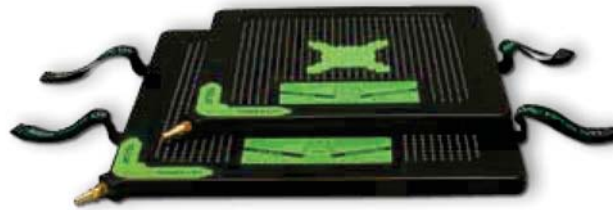

Lifting Capacity and Height Guidelines

When selecting the proper air bag arrangement, consider size and lift requirements. The amount of contact surface is a direct relationship to force output. It's important to consider the lifting height when sizing the proper air bag. As an air lifting bag inflates (increasing convexity), contact surface is reduced, which lowers the lifting capacity.

Air bags stacked on top of each other will increase the lifting height, but not the overall air bag capacity. Lifting capacity depends on the size of the air bag surface in contact with the lower surface of the object to be lifted. In order to choose the proper size air bag, reference the performance graph on page 98.

Example below demonstrates a typical 44 ton two air bag system arrangement.

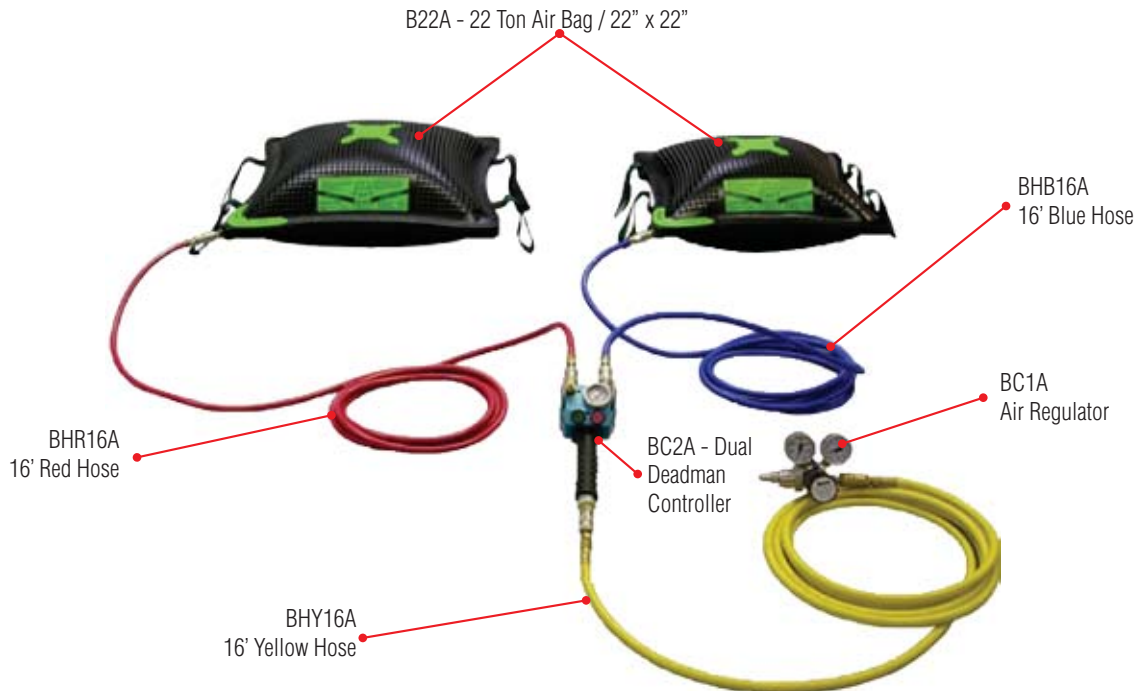

LIFTING JACKS

HJ Series - Hand Jacks

SIMPLEX



HJ2A, HJ3A and HJ8A Family Shown

Capacity Range▶ 2 - 100 tons
 Stroke Range▶ 2.44 - 5.91 in.
 Weight▶ 7.9 - 191.8 lbs.

- ▶ Thick base material with large area for increased strength and stability during lifting.
- ▶ High strength beam and pump linkage for long life.
- ▶ Safety relief valve to prevent overload.
- ▶ All models include over-travel protection.
- ▶ Lever Bar included on all models.

SCREW EXTENSIONS

2 through 22 ton models include screw extensions with cleated saddle for quick setup.



LEVER BARS

All Hand Jacks come equipped with a 3 piece Lever Bar set to accommodate space limitations.



Various applications are suitable for the hydraulic HJ Series hand Jack, ranging from spreading, leveling, lifting and holding. ▼



Model	Capacity (tons)	Stroke (in)	Minimum Height (in)	Extended Screw Height (in)	Maximum Height (in)	Base Area (in)	Piston Diameter (in)	Maximum Handle Effort (lbs)	Weight (lbs)
HJ2A	2	3.94	6.30	1.97	12.20	3.74 X 4.37	0.83	82	7.9
HJ3A	3	4.13	6.61	2.56	13.31	3.74 X 4.57	0.94	108	9.0
HJ5A	5	5.91	8.35	2.95	17.20	3.74 X 4.84	1.14	95	11.0
HJ8A	8	5.91	8.62	2.95	17.48	3.74 X 5.43	1.29	86	13.0
HJ11A	11	5.91	8.62	2.95	17.48	3.74 X 5.59	1.47	106	14.3
HJ11ALP	11	2.44	5.16	1.18	8.78	3.74 X 5.59	1.47	106	12.1
HJ22A	22	5.91	9.21	2.95	18.07	5.00 X 6.73	2.00	108	26.7
HJ22ALP	22	4.13	7.48	2.17	13.78	5.00 X 6.73	2.00	108	22.0
HJ35A	35	5.91	9.68	*	15.59	7.09 X 8.44	2.75	97	51.81
HJ55A	55	5.91	9.92	*	15.83	7.09 X 9.06	3.15	104	62.8
HJ100A	100	5.91	11.81	*	17.72	11.65 X 13.11	4.33	71	191.8

Lifting Jacks



TJH Family Shown

Capacity Range▶ 2 - 10 tons
Stroke Range▶ 4.44 - 9 in.
Weight▶ 18 - 85 lbs.

- ▶ Self-contained models for maximum versatility.
- ▶ Low toe heights fit in tight clearances.
- ▶ The lowest handle effort for easy operation.
- ▶ The lowest weights for reduced back injuries.
- ▶ Swivel sockets for access in close quarters. (TJH5 & TJH10 only).
- ▶ Lever Bars are included with all models.



LEVER BARS
TJH2, TJH5 and TJH10 Toe Jacks come equipped with a 3 piece Lever Bar set to accommodate space limitations.



LEVER BAR
TJH109LS Toe Jack comes equipped with a solid one piece Lever Bar.



TOE LIFT
Toe Lifts are rated at maximum capacity on all models.



PISTOL GRIP
TJH109LS comes equipped with an ergonomic pistol grip for rapid advancement to load.

Its small footprint and ease of mobility make the TJH10 perfect for lifting a variety of equipment when space and clearance are at a premium.▼



Lifting Jacks

Model	Capacity (tons)	Stroke (in)	Minimum Height (in)		Base Area (in)	Maximum Handle Effort (lbs)	Method Of Return	Weight (lbs)
			Toe (in)	Cap (in)				
TJH2	2	4.44	.62	9.25	4.92 x 7	51	Load	18
TJH5	5	4.62	1	11.75	7.25 x 10.62	33	Spring	53
TJH10	10	5.87	1.25	13.13	9.5 x 11.25	38	Spring	85
TJH109	10	9	2.25	22	6.5 x 10	80	Spring	56
TJH109LS	10	9	2.17	16.13	6 x 9	73	Spring	41

LIFTING JACKS

B Series - Air Lifting Bags

SIMPLEX



B Series Shown

Capacity Range► 11 - 74.1 tons

Lifting Height► 2.7 - 20 in.

Maximum Pressure► 116 psi

- 11 models with capacities ranging from 1.1 through 74.1 tons.
- Simplex air bags operate on standard shop air up to 116 psi.
- All models include 2 ply Kevlar with neoprene.
- Wide variety of safety controllers for single & multiple bag systems.
- Light weight makes the Simplex air bags easy to set up.
- B22A through B74A bags come with side holes for attaching bags together.

THINK SAFETY

Please refer to pages 4&5 for a complete list of safety tips and recommendations.



Y CONNECTOR - pages 100 - 101

Allows control of two bags from one single fitting controller.



DUAL DEADMAN CONTROLLER - pages 100 - 101

Used for precise inflation and deflation control.



Air Bag Performance

B1A Through B6A Air Bag Chart

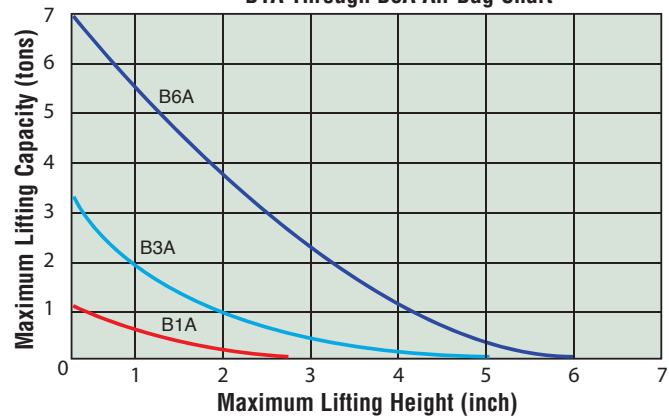

B11A Through B74A Air Bag Chart

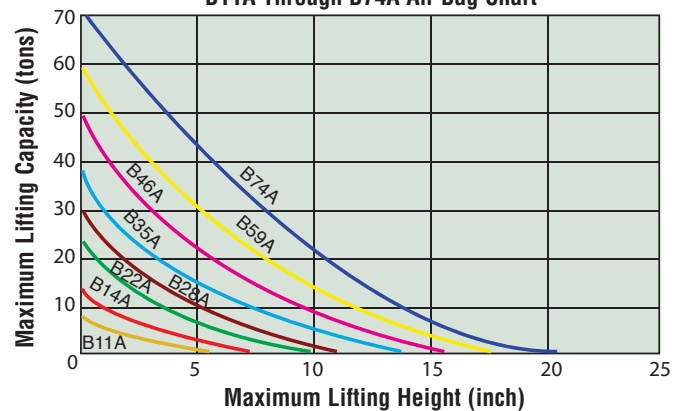

Durability and strength makes Simplex Air Lifting Bags the perfect solution to raise these collapsed concrete slabs for repair. ▼



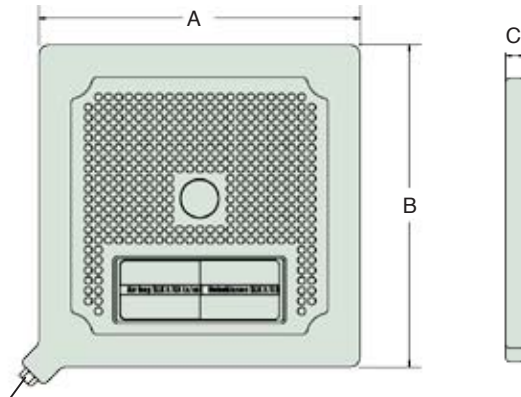









1/4" - 18 NPTF

Model	Capacity (tons)	Maximum Lifting Height (in)	A	B	C	Air Required @ 116 PSI (cu.ft.)	Maximum Burst Pressure (PSI)	Weight (lbs)
			Length (in)	Width (in)	Thick (in)			
B1A	1.1	2.7	6	6	1.1	.18	464	1.32
B3A	3.1	5.1	9	9	1.1	.53	464	2.8
B6A	6.4	5.9	12	12	1.1	1.48	464	5.3
B11A	10.8	7.0	15	15	1.1	3.04	464	8.8
B14A	14.2	8.6	18	18	1.1	5.37	464	11.6
B22A	22.7	10.6	22	22	1.1	10.45	464	17.8
B28A	27.7	11.8	24	24	1.2	14.7	464	24.6
B35A	35.3	14.1	27	27	1.2	21.9	464	29.9
B46A	46.4	16.5	31	31	1.2	32.5	464	40.1
B59A	58.8	17.7	35	35	1.2	46.8	464	49.6
B74A	74.1	20	36	36	1.2	53.1	348	55.8

Lifting Jacks

Model		Description
	<p>BHR16A - 16' Red Hose</p> <p>BHR32A - 32' Red Hose</p> <p>BHB16A - 16' Blue Hose</p> <p>BHB32A - 32' Blue Hose</p> <p>BHY16A - 16' Yellow Hose</p> <p>BHY32A - 32' Yellow Hose</p>	<p>Industrial duty, color coded Supply Hoses allows the user to coordinate the lift properly and safely.</p>
	<p>BC12</p>	<p>Deluxe Dual Deadman Controller used for precise inflation and deflation control. Built in safety relief valves prevent over inflation with the pressure sensitive toggles.</p>
	<p>BC2A</p>	<p>Dual Deadman Controller with pressure gauge and pressure relief valves. Control two bags from one air source. Reliable over extreme temperature range.</p>
	<p>BC3A</p>	<p>Single Deadman Controller with pressure gauge and pressure relief valves. Reliable over extreme temperature range.</p>

Model	Description
	<p>BC9A</p> <p><i>Y Connector</i> allows control of 2 bags from one single fitting controller.</p>
<p>BC8A</p>  <p>BC6A</p>	<p>BC8A</p> <p>BC6A</p> <p><i>In-Line Control Shut Off and Relief Valves</i> enable the user to disconnect a hose without deflating the bag.</p>
	<p>BC11</p> <p><i>Dual Safety Controller</i> with pressure gauge and pressure relief valve. Cost effective and reliable over a wide range of control applications.</p>
	<p>BC1A</p> <p><i>Pressure Regulator Controller</i> is a diaphragm type single stage regulator with high pressure air tank compatibility.</p>
	<p>BC4A</p> <p><i>Single Safety Controller</i> with pressure gauge and pressure relief valve. Cost effective and easy to use.</p>

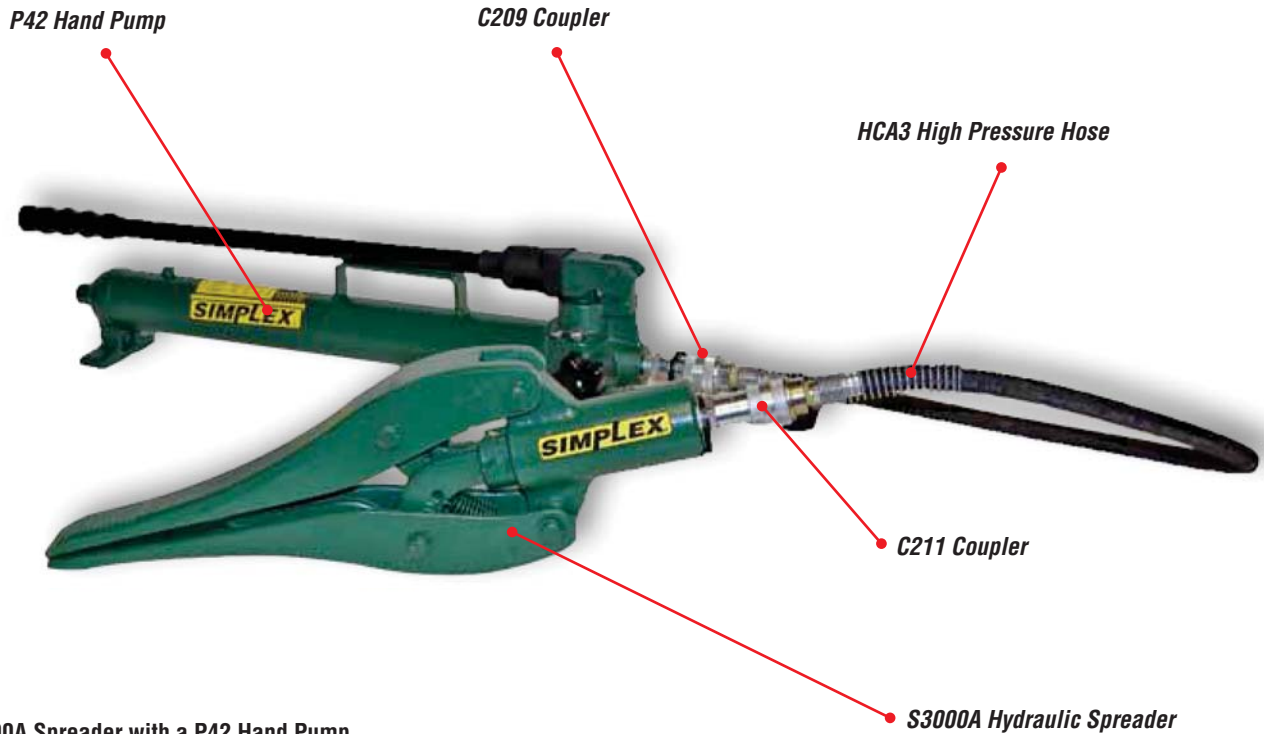

PRODUCT LINE OVERVIEW

► Specialty Tools

Whether it's a construction site or production fabrication, Simplex single acting 35 ton portable punch offers fast and effective solutions.

► Spreaders

From flange spreading to emergency rescue, Simplex can supply a suitable solution in hydraulic or mechanical spreading.

► Configured to Meet a Broad Range of Requirements

Whether it's collision repair, general maintenance or specialized spreading, clamping or holding, Simplex maintenance kits come complete with the largest assortment of attachments.

Hydraulic Nut Splitters

Simplex nut splitters fit up to 8 nut sizes and offer greater value and versatility. The specifically designed head fits all A.P.I. and ANSI flanges and cuts nuts .5" to 2.88". You can easily calibrate the cutting chisel so only the nut is cut without damaging the bolt or stud. Simplex splitters will cut the hardest nuts, up to grade 8 and 2H (ASTMA 194/2H), Brinell hardness 248-325.



Hydraulic Spreaders

The Simplex S2000A (1 ton) and S3000A (.75 ton capacity) spreaders are the perfect fit for close clearance jobs. The SF5 spreader offers 5 tons of spreading force with a .13" starting clearance. It is one of Simplex's most versatile tools for spreading.



Single Acting Portable Punch

Simplex 35 Ton Single-Acting Portable Punch mounted motor control handle (included with SPH35A) provides easy operation and greater operator safety. Punches and dies are interchangeable with competitive punches.



Hydraulic Maintenance Kits

The Simplex MK106 Maintenance Kit provides a complete assortment of attachments that greatly expands the range of applications. Using these various attachments allows you to custom build spreaders, straightening tools, clamps and a wide variety of other problem solving maintenance tools.



HYDRAULIC TOOLS

SPH Series - Single Acting Punch

SIMPLEX



SPH35A Shown

Capacity ▶ 35 tons
 Maximum Thickness ▶ .5 in.
 Maximum Pressure ▶ 10,000 psi

- ▶ Industrial grade, single acting, spring return design.
- ▶ Punches holes in material up to .5" thick mild steel.
- ▶ All models come equipped with a heavy duty steel case, providing tool and die organization along with ease of transport.
- ▶ Large selection of square, rounded and oblong dies and punches are offered to complete a wide variety of applications.

HOSES - pages 78 - 79



Heavy duty and thermo plastic hydraulic hoses to meet your requirements and safety factor.

POWER PUMPS - pages 43 - 65



Simplex offers a wide variety of lightweight power pumps to fit any application.

GAUGES - page 77



Improve your system visibility and safety by adding an inline hydraulic gauge to your circuit.

Simplex offers a punch mounted motor control so that work can be performed safely and more productively as shown in this fabricating shop. ▼

SPH35SPA Kit Includes:

Punch - Case - Punch & Die Set - Pump - Hose



Model	Punch	Steel Case	Punch & Die Set	Pump	Pump Voltage	Hose	Weight Punch Only (lbs.)
SPH35A	SPH35A	Yes	----	----	----	----	32
SPH35SA	SPH35A	Yes	DS-44, DS-56, DS-69, DS-81	----	----	----	32
SPH35SPA - 115	SPH35A	Yes	DS-44, DS-56, DS-69, DS-81	G1101F	115	HCA6	32
SPH35SPA - 230	SPH35A	Yes	DS-44, DS-56, DS-69, DS-81	G1201F	230	HCA6	32
*SPH35MA	SPH35A	Yes	DS-38, DS-44, DS-53, DS-69	----	----	----	32
*SPH35MPA - 115	SPH35A	Yes	DS-38, DS-44, DS-53, DS-69	G1101F	115	HCA6	32
*SPH35MPA - 230	SPH35A	Yes	DS-38, DS-44, DS-53, DS-69	G1201F	230	HCA6	32

* "M" = METRIC DIE SET

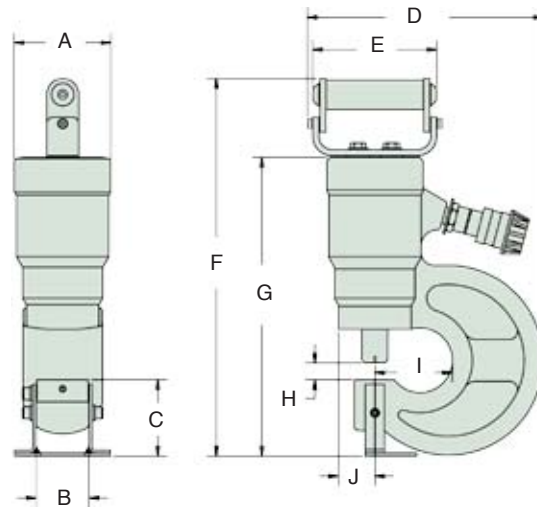

Punch Dimensions

	A	B	C	D	E	F	G	H	I	J
Imperial	3.75	2.06	2.97	9.16	4.81	14.66	11.6	.66	3	1.42
Metric	95.25	52.32	75.43	232.66	122.17	372.36	294.64	16.76	76.2	36.06

QUALITY OF STEEL REFERENCE TABLE

A: Mild A-7
 B: Boiler Plate
 C: Structural A-36
 D: Struct Corten (ASTM A242)

E: Cold Rolled C-1018
 F: Hot Rolled C-1050
 G: Hot Rolled C-1095
 H: Hot Rolled C-1095 Annealed

I: Stainless Annealed
 J: Stainless 304 Hot Rolled
 K: Stainless 316 Cold Rolled

Contact Factory for additional dimensions.

Hole Type	Punch Model	Die Model	Punch & Die Set	Bevel Punch & Die Set for I-Beams	Bevel Punch & Die Set for U-Beams	Hole Size		Bolt Size		A	B	C	D	E	F	G	H	I	J	K
						(in)	(mm)	(in)	(mm)	*Maximum Metal Thickness To Be Punched (in.)										
Round	DP-31	DD-31	DS-31	DSB-31	---	.31	7.9	.25	---	.31	.31	.25	.25	.25	.25	.13	.19	.25	.25	.25
Round	DP-38	DD-38	DS-38	DSB-38	---	.38	9.5	.31	M8	.38	.38	.31	.31	.31	.31	.19	.25	.31	.31	.31
Round	DP-44	DD-44	DS-44	DSB-44	DSBU-44	.44	11.1	.44	M10	.44	.44	.38	.38	.38	.31	.19	.31	.31	.31	.31
Round	DP-53	DD-53	DS-53	DSB-53	DSBU-53	.53	13.5	.44	M12	.50	.50	.44	.44	.44	.38	.25	.31	.38	.38	.38
Round	DP-56	DD-56	DS-56	DSB-56	---	.56	14.3	.5	---	.50	.50	.50	.44	.50	.44	.25	.38	.44	.44	.44
Round	DP-69	DD-69	DS-69	DSB-69	DSBU-69	.69	17.5	.62	M16	.50	.50	.50	.44	.50	.40	.25	.31	.40	.40	.40
Round	DP-78	DD-78	DS-78	---	---	.78	19.8	---	M18	.50	.50	.50	.44	.50	.38	.25	.31	.38	.39	.38
Round	DP-81	DD-81	DS-81	---	---	.81	20.6	.75	---	.50	.50	.50	.44	.50	.31	.19	.31	.31	.31	.31
Square	DP-45	DD-45	DS-45	---	---	.31	7.9	.25	---	.31	.31	.25	.25	.25	.25	.13	.19	.25	.25	.25
Square	DP-54	DD-54	DS-54	---	---	.38	9.5	.31	M8	.38	.38	.31	.31	.31	.31	.19	.25	.31	.31	.31
Square	DP-63	DD-63	DS-63	---	---	.44	11.1	.38	M10	.44	.44	.38	.38	.38	.31	.19	.31	.31	.31	.31
Square	DP-72	DD-72	DS-72	---	---	.50	12.7	.44	M12	.50	.50	.44	.44	.44	.38	.25	.31	.38	.38	.31
Oblong	DP-10	DD-10	DS-10	---	---	.31 x .75	7.9 x 19	.25	---	.31	.31	.25	.25	.25	.25	.13	.19	.25	.25	.25
Oblong	DP-12	DD-12	DS-12	---	---	.38 x .75	9.5 x 19	.19	M8	.38	.38	.31	.31	.31	.31	.19	.25	.31	.31	.31
Oblong	DP-18	DD-18	DS-18	---	---	.44 x .75	11.1 x 19	.38	M10	.44	.44	.38	.38	.38	.31	.19	.31	.31	.31	.31
Oblong	DP-25	DD-25	DS-25	---	---	.50 x .75	12.7 x 19	.44	M12	.50	.50	.44	.44	.44	.38	.25	.31	.38	.38	.38



Capacity Range ▶ .75 - 1 ton
 Weight ▶ 5 - 25 lbs.
 Spread Range ▶ .38 - 11.5 in.

- ▶ Closed narrow ends starting at .38".
- ▶ Large spreading range up to 11.5".
- ▶ Return spring assists the jaws to the closed position.
- ▶ Durable all metal construction to withstand any tough environment.
- ▶ Quality high flow coupler for fast tool setup.

S2000A and S3000A Shown

HOSES - pages 78 - 79



Heavy duty and thermo plastic hydraulic hoses to meet your requirements and safety factor.



POWER PUMPS - pages 43 - 65

Simplex offers a wide variety of lightweight power pumps to fit any application.

COUPLERS - pages 74 - 75



High flow quick disconnect couplers provide a quick change to a variety of pumps.

Hydraulic Tools

S2000A

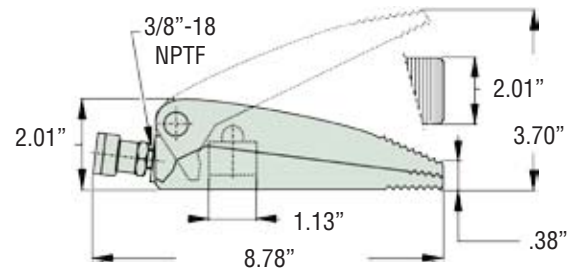

S3000A

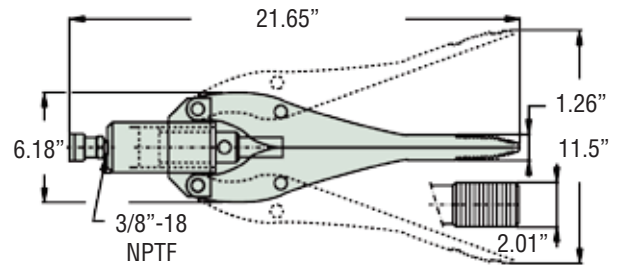

The Simplex S2000A spreader was used to remove this rusted anchor plate from a brick wall for mortar patching to begin. ▼



Model	Capacity (tons)	Pressure @ Capacity (PSI)	Oil Capacity Required (cu.in.)	Weight (lbs)	Width (in)	Suggested Hand Pump
S2000A	1	10,000	.61	5	2.01	P42
S3000A	.75	10,000	3.91	25	2.01	P42



SF5 Shown

- Capacity ▶ 5 tons
- Weight ▶ 17 lbs.
- Spread Range ▶ .13 - 3 in.

- ▶ 5 tons of spreading force.
- ▶ .13" through 3" spreading capability.
- ▶ Jaws open parallel.
- ▶ Will not drift or creep-down.
- ▶ All metal construction.



GAUGES - page 77

Improve your system visibility and safety by adding an inline hydraulic gauge to your circuit.



HAND PUMPS - pages 31 - 41

Handpump design specifications meet or exceed ANSI /ASME B30.1 Safety Standards.



◀ SF5 Spreaders are used in pairs to spread the flanges equally for general maintenance and repair.

Boasting 5 tons of spreading force and 3 inches of operational lift, the SF5 is the most versatile tool for heavy equipment maintenance. ▼

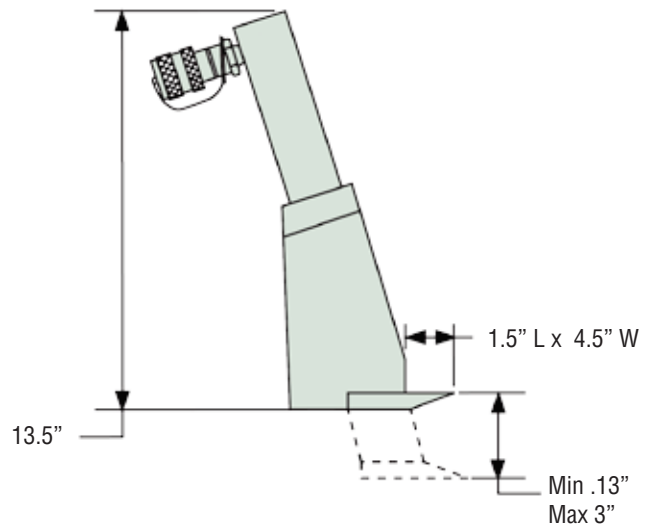

Model	Capacity (tons)	Oil Capacity Required (cu.in.)	Pressure @ Capacity (PSI)	Weight (lbs)	Spread		Suggested Hand Pump
					Min. (in)	Max. (in)	
SF5	5	5	10,000	17	.13	3	P22

HYDRAULIC TOOLS

NS Series - Nut Splitters

SIMPLEX



NS Series Shown

Nut Range► .5 - 2.88 in.

Weight► 1.8 - 75.1 lbs.

Maximum Pressure► 10,000 psi

- Cuts hardened nuts up to grade 8 & 2H.
- Replacement chisel and set screws included.
- Cuts nuts from .5" to 2.88".
- Rugged carrying case included.
- Not designed to cut square nuts.

HOSES - pages 78 - 79



Heavy duty and thermo plastic hydraulic hoses to meet your requirements and safety factor.

THINK SAFETY



Please refer to pages 4&5 for a complete list of safety tips and recommendations.

COUPLERS - pages 74 - 75



High flow quick disconnect couplers provide a quick change to a variety of pumps.

Refineries, steel mills and power plants rely heavily on Simplex nut splitters for removing stubborn or rusted nuts easily and safely. ▼

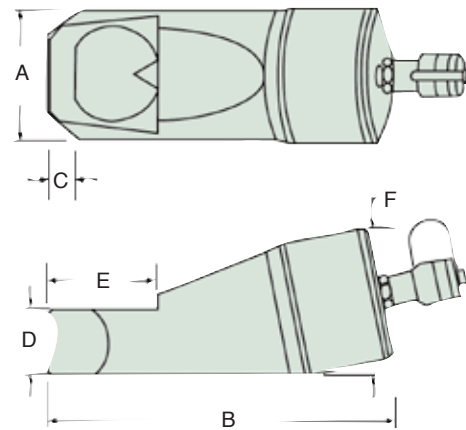

Model	Stud Diameter (in)	Nut A/F (in)	A (in)	B (in)	C (in)	D (in)	E (in)	F (in)	Wgt. (lbs.)	Suggested Hand Pump
NS1319	.25 - .44	.5 - .75	1.57	4.76	.28	.75	1.14	1.93	1.8	P42 / P72
NS1924	.44 - .56	.75 - .94	2.13	5.77	.39	.98	1.57	2.42	4.4	P42 / P72
NS2432	.56 - .75	.94 - 1.13	2.52	7	.51	1.18	2.05	2.99	6.6	P42 / P72
NS3241	.75 - 1	1.13 - 1.56	2.97	8.09	.63	1.42	2.56	3.38	9.7	P42 / P72
NS4150	1 - 1.25	1.56 - 2	3.70	9.61	.83	1.77	3.00	4.17	18	P140
NS5060	1.25 - 1.5	2 - 2.25	4.17	10.60	.94	2.13	3.62	4.90	26	P140
NS6075	1.5 - 1.87	2.38 - 2.88	6.26	14.37	1.06	2.95	4.37	7.20	75.1	P140

Capacity▶ **10 tons**

Weight▶ **84 lbs.**



- ▶ Set includes a Simplex hand pump, cylinder, hose, gauge and gauge adapter.
- ▶ Heavy duty case included.
- ▶ Rated at 5 tons when attachments are used.
- ▶ Quick lock and threaded adaptors included.
- ▶ Order as a set or individual components.

MK106 Shown



THINK SAFETY

Please refer to pages 4&5 for a complete list of safety tips and recommendations.



R106 is rated at 10 tons at 10,000 psi. When using attachments or extensions do not exceed 5,000 psi (5 tons) reading on the gauge. Accessories & extensions are only rated at 5 tons. S2000A Spreader has an operating capacity of 1 ton.



◀ Add collar toe and flat base to build custom spreader or toe jack.



◀ Extensions, custom heads and adapters allow you to create tools that solve hundreds of problems. Simplex MK106 kits are used extensively for collision repair.



◀ Add a V-base and flat base for special spreading, holding and bending jobs.







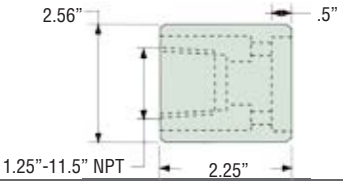

Hydraulic Tools

Model	Capacity (tons)	Cylinder	Hand Pump	Hose	Gauge	Gauge Adapter	Attachments	Spreader	Box	Weight (lbs)
MK106	10	R106	P42	HCA6	G5	GA1	MK-4 thru MK-20	S2000A	MK-21	84

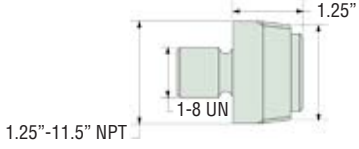
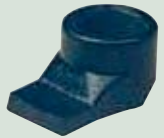
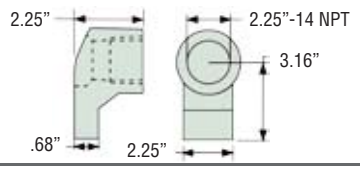
HYDRAULIC TOOLS

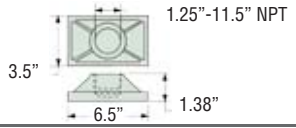
MK Series - Kit Components

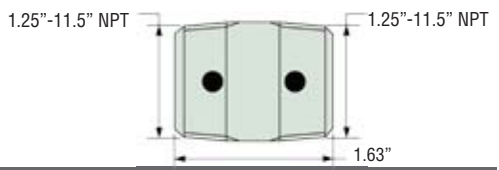
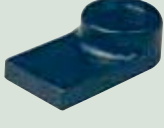
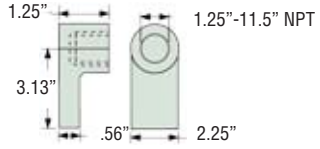

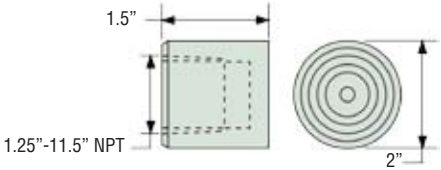







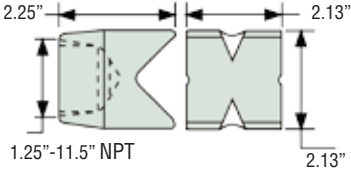

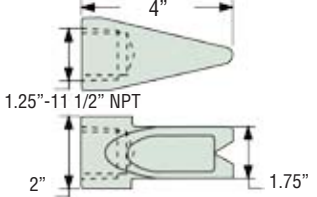

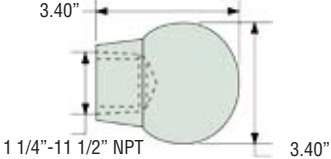

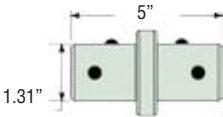
SIMPLEX

Model	Description	Dimensions
 MK-4	Base Attachment (Qty. 1)	
 MK-5	Threaded Adaptor (Qty. 1)	
 MK-6	Collar Toe (Qty. 1)	
 MK-7	Flat Base (Qty. 1)	
 MK-8	Threaded Connector (Qty. 1)	
 MK-9	Threaded Plunger Toe (Qty. 1)	
 MK-10	Grooved Saddle (Qty. 1)	

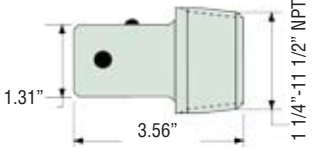
Hydraulic Tools

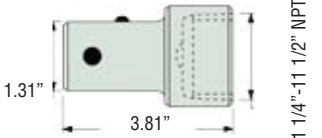

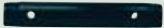
Maintenance Kit - MK106

Model	Description	Dimensions
 MK-11	90° V-Base (Qty. 1)	
 MK-12	Wedge Head (Qty. 1)	
 MK-13	Flex Head (Qty. 1)	
 MK-14	Lock On Connector (Qty. 3)	
 MK-15	Lock Pin (Qty. 4)	
 MK-16	Male Lock On Adapter (Qty. 1)	
 MK-17	Female Lock On Adapter (Qty. 1)	
Extensions and Box		
 MK-18	5 Inch Extension Pipe (Qty. 1)	
 MK-19	10 Inch Extension Pipe (Qty. 1)	
 MK-20	18 Inch Extension Pipe (Qty. 1)	
 MK-21	Wooden Box (Qty. 1)	

* All components are included in the MK106 Maintenance Kit.
 * All components can be ordered separately.

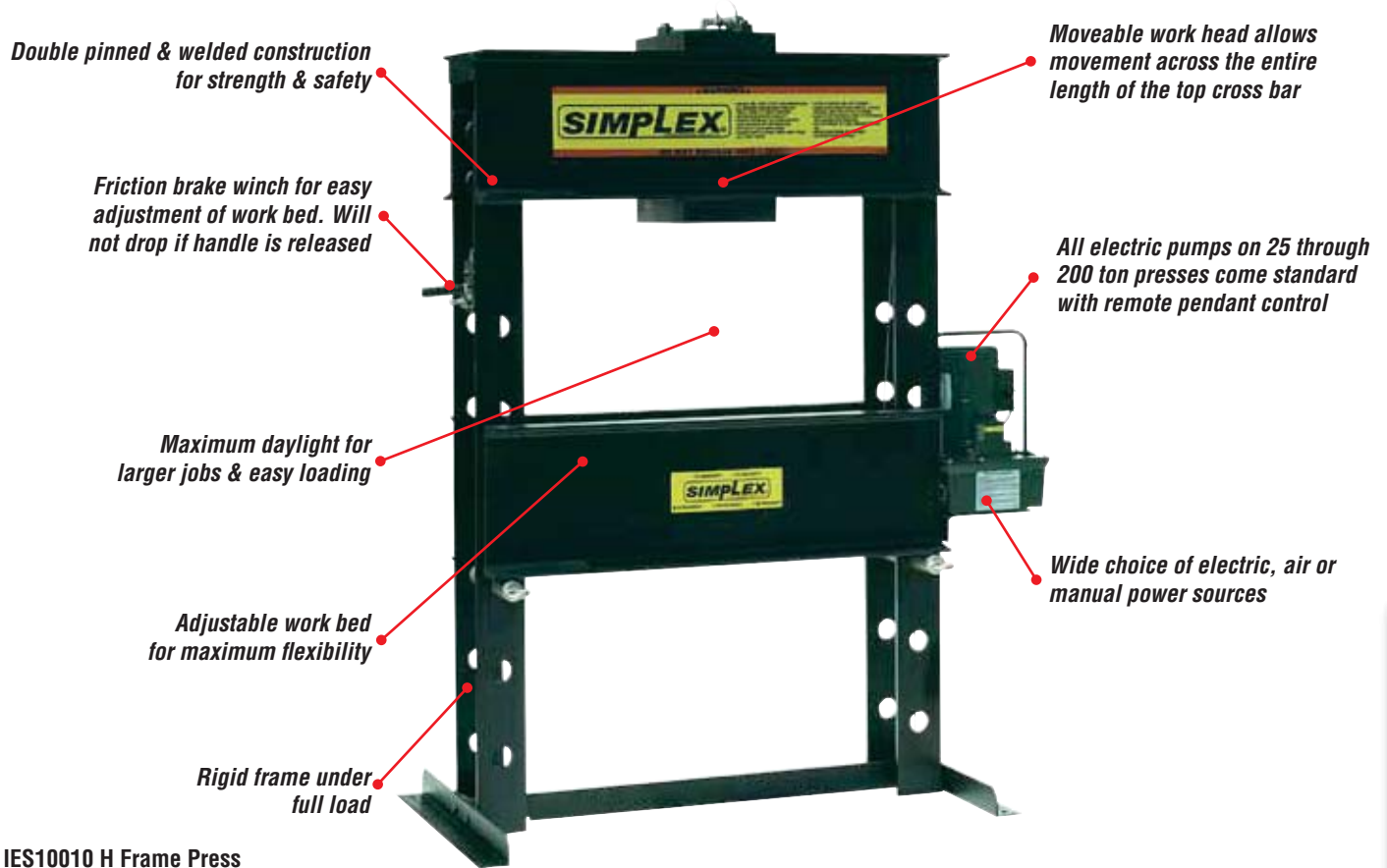

IES10010 H Frame Press

PRODUCT LINE OVERVIEW

► Wide Variety

Simplex offers presses with capacities from 10 through 200 tons. Choose from a wide range of pressing, cylinder strokes & styles, and your choice of Simplex manual or power pumps. Choose from a variety of H-Frame designs.

► Heavy Duty Construction/ Built for Safety

Simplex presses do not rely on "bolt together" construction for strength. Simplex H-Frames employ double pinned and heavy duty welded construction. This construction provides a frame that is **rigid** and provides an extra margin of safety.

► Maximum Flexibility

All Simplex H-Frame Presses include a moveable work head that easily rolls across the entire length of the top cross bar. This allows the pressing force to be positioned at any point of the press bed. The adjustable work bed can be raised or lowered to accommodate a wide variety of jobs.

► Maximum Daylight

Simplex presses have large work areas that accommodate larger jobs and makes loading and unloading easier. Open sides have large clearances for loading work through the side daylight.

► Easy To Use

H-Frame (25 ton & up) includes a friction brake winch that adjusts the bed height effortlessly and will not drop the bed if the handle is released (no kick back). The wide choice of pumps & valves provides a variety of controls. Moveable work head incorporates rollers for easy positioning.

► Custom Build Your Press

Along with many standard models, you can build custom presses by ordering the press without a pump. Order any Simplex pump & pump mounting kit separately to meet your requirements.

Selecting A Hydraulic Press

SIMPLEX Hydraulic H-frame presses are accepted in many industries because of their wide range of use. They are able to produce significant force, ranging from 10 through 200 tons. Hydraulic presses provide force through the use of fluid pressure on a piston by means of manual or powered pumping element. The power source provides the ability for infinite adjustment of stroke, speed, length and pressure while staying within the limits of press capacity. Refer to the individual presses for packaged systems.

Principal Parts To Review

Throat Clearance - The distance from the vertical centerline of the ram to the frame member at the back of the bed. The distance measures the largest diameter piece that can be positioned with the part centerline under the center of the ram.

Daylight - The vertical clearance from the top of the bed to the underside of the ram in its peak position upwards. It shows the maximum vertical capacity of the press.

Work Height - *The distance from the floor to the bolster.*

Simplex Hydraulic Presses

Hydraulic Presses



Bench

Only Simplex offers Bench Presses with up to 15 ton capacities, moveable work heads and adjustable beds for maximum flexibility. For small production jobs, the adjustable bed eliminates wasted time approaching the work. IBP1010 & IBP1510 presses include a 10" stroke cylinder.



Floor H - Frame

Simplex H-Frame Presses can be used professionally for assembly or straightening work up to 200 tons. They are also excellent for testing work pieces. H-Frame presses are robust and built to last. The frame is made of welded steel sections and the hydraulic system is excellent for precision work with the height of the work table easy to adjust and the cylinder head moveable.

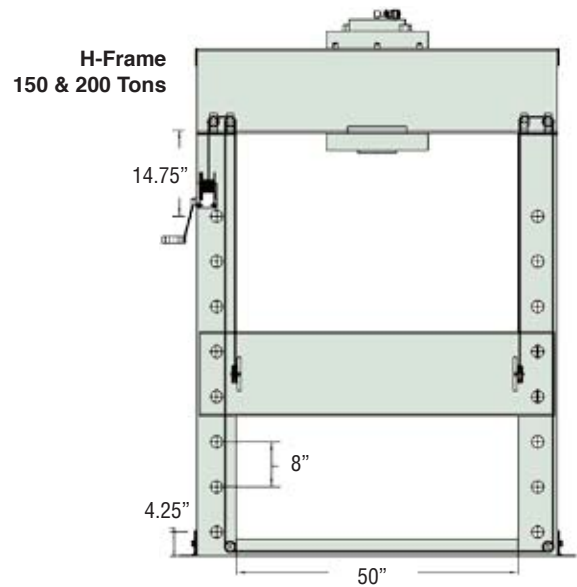
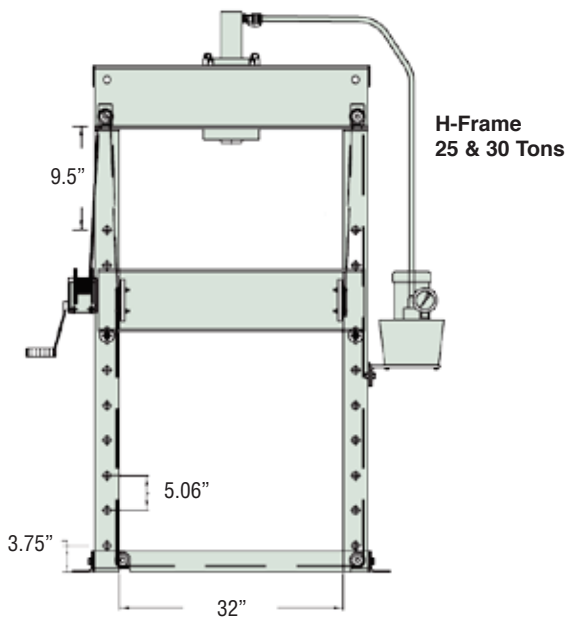
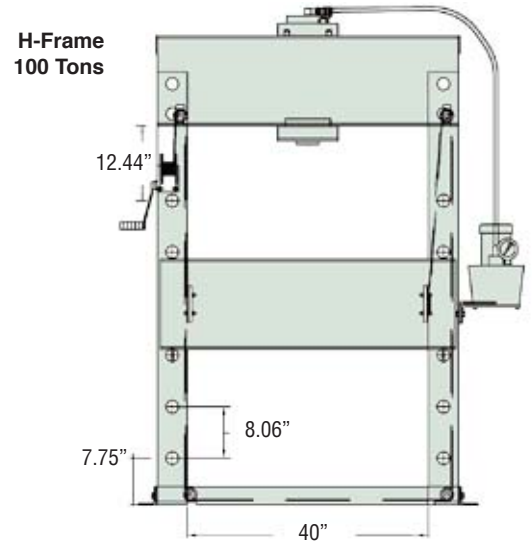
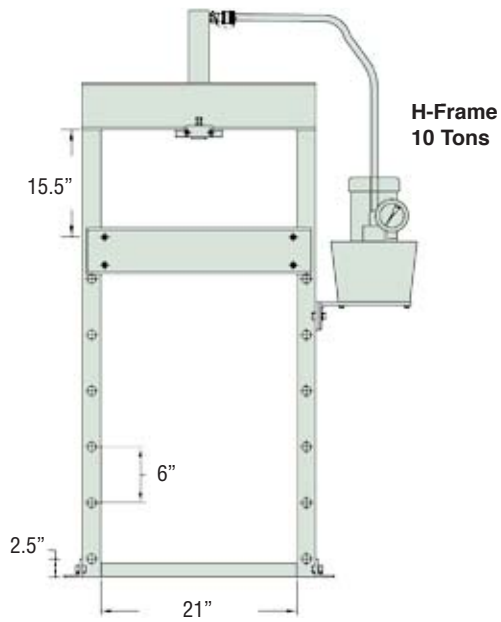
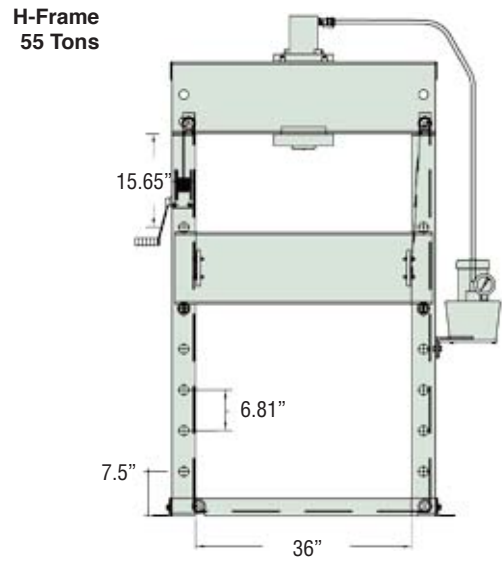
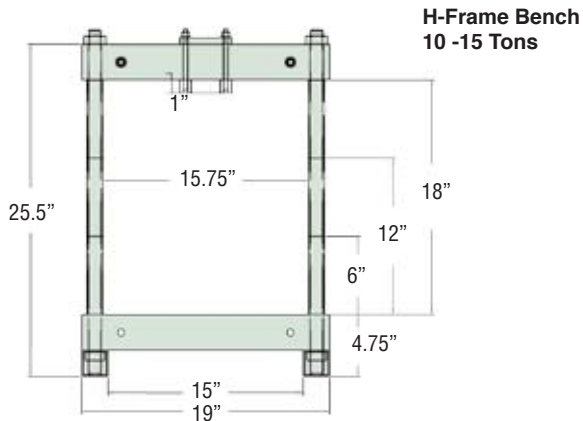

HYDRAULIC PRESSES

10 - 15 Ton - H Frame Bench

SIMPLEX



Capacity▶ 10 - 15 tons

Stroke▶ 10 in.

Maximum Pressure▶ 10,000 psi

- ▶ 10 or 15 ton capacities.
- ▶ Adjustable bed with large daylight.
- ▶ Moveable work head.
- ▶ Wide variety of power sources.

IBP1010 Shown

COUPLERS - pages 74 - 75

High flow quick disconnect couplers provide a quick change to a variety of pumps.



SIMPLEX CYLINDERS - pages 7 - 29

Cylinder design specifications meet or exceed ANSI /ASME B30.1 Safety Standards.



Hydraulic Presses

Simplex bench mounted press frame simplified the work so it can be performed safely and more productively.▼

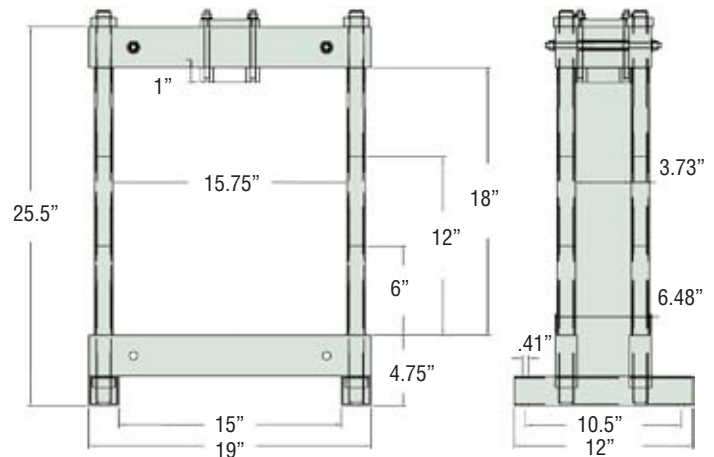

Contact Factory for additional dimensions.

Model Number with Cylinder	Capacity (tons)	Type	Ram	Stroke (in)	Model Number w/o Cylinder	Weight (lbs)
IBP1010	10	S/A	R1010	10	IBP10	142
IBP1510	15	S/A	R1510	10.38	IBP15	150

Products listed below are ordered separately.

Capacity (tons)	Suggested Hand Pump	Suggested Electric Pump	Suggested Hose	Suggested Gauge	Gauge Adapter	Weight (lbs)
10	P42	G1121	HCA6	G6	GA1	130
15	P42	G1121	HCA6	G6	GA1	130



IMS1010 Shown

Capacity ▶ 10 tons
 Stroke ▶ 10 - 10.13 in.
 Maximum Pressure ▶ 10,000 psi

- ▶ Single or double acting models available.
- ▶ Large daylight with open sides for easy loading.
- ▶ Heavy duty welded construction.
- ▶ Moveable work head for maximum versatility.
- ▶ IES Series comes with motor pendant control.



HAND PUMPS - pages 31 - 41
 Handpump design specifications meet or exceed ANSI /ASME B30.1 Safety Standards.



POWER PUMPS - pages 43 - 65
 Simplex offers a wide variety of lightweight power pumps to fit any application.

PUMP MOUNTING KIT

For Hand Pumps Model IM2
 Order # 40959

For Power Pumps Model IM3
 Order # 40960

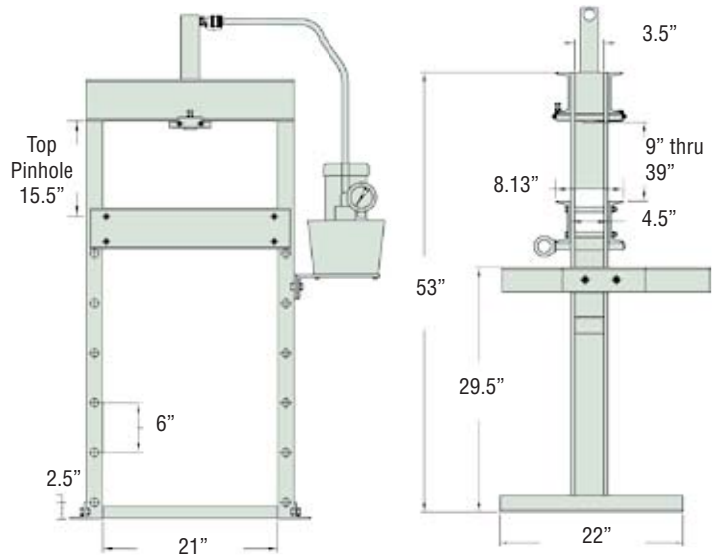

Hydraulic Presses

Model Number Without Pump	Model Number With Pump	Type of Cylinder	Cylinder Stroke (in)	Type of Pump	Pump Model	Operation	Speed (in/min) * Indicates Inches per Stroke		Weight With Pump (lbs)	Weight Without Pump (lbs)
							Advance	Pressing		
----	IAS1010	R1010 Single Acting 10 Ton Capacity	10	Air Powered	GA90	Advance Hold Retract	31	4.5	202	172
IS1010	IES1010		10	Electric Powered	G1121		104	9	204	172
----	IMS1010		10	Manual	P42		.38*	.06*	208	172
IDD1010	IED1010	RDA1010 D/A	10	Electric Powered	G1141		104	9	226	188
----	IMD1010	10 Ton Capacity	10	Manual	P140D		1.25*	.10*	236	188

HYDRAULIC PRESSES

25 - 30 Ton - H Frame

SIMPLEX



IES256 Shown

Capacity Range▶ 25 - 30 tons
 Stroke▶ 6.25 - 14.25 in.
 Maximum Pressure▶ 10,000 psi

- ▶ Large daylight with open sides for easy loading.
- ▶ Wide choice of pumps & pressing cylinders.
- ▶ Includes tonnage gauge.
- ▶ IES & IED Series comes with pendant control.
- ▶ Moveable work head for maximum versatility.
- ▶ Adjustable work bed with friction brake winch.

COUPLERS - pages 74 - 75



High flow quick disconnect couplers provide a quick change to a variety of pumps.

HAND PUMPS - pages 31 - 41



Handpump design specifications meet or exceed ANSI /ASME B30.1 Safety Standards.

PUMP MOUNTING KIT

For Hand PumpsModel IM2
 Order # 40959

For Power PumpsModel IM3
 Order # 40960

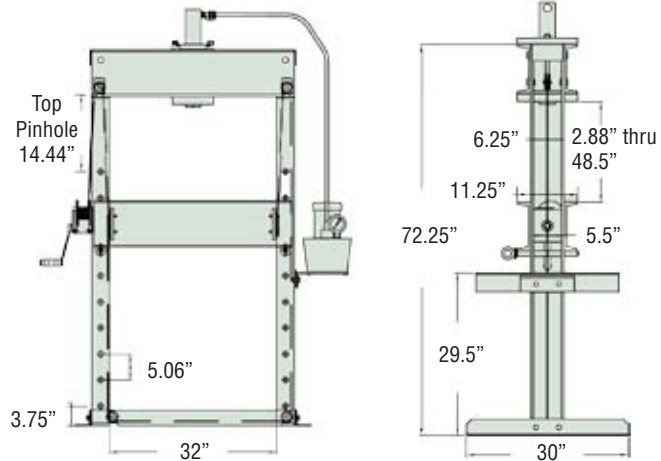

Hydraulic Presses

* For Presses with an electric 230V pump, add an "A" to the end of the model number.

Model Number Without Pump	* Model Number With Pump	Type of Cylinder	Cylinder Stroke (in)	Type of Pump	Pump Model	Operation	Speed (in/min) * Indicates Inches Per Stroke		Weight With Pump (lbs)	Weight Without Pump (lbs)
							Advance	Pressing		
----	IAS256	R256/ R2514 Single Acting 25 Ton Capacity	6.25	Air	GA90	Advance Hold Retract	14	2	417	----
----	IAS2514		14.25	Air	GA90		14	2	433	----
IS256	IES256		6.25	Electric 115V	G1121		50	4	419	387
IS2514	IES2514		14.25	Electric 115V	G1121		50	4	435	403
----	IMS256		6.25	Manual	P82A		.15*	.03*	423	----
----	IMS2514		14.25	Manual	P82A		.15*	.03*	439	----
ID3014	IED3014	RDA3014	14.25	Elec. 115V	G4172	40	3	462	428	
----	IMD3014	RDA3014	14.25	Manual	P140D	.43*	.04*	458	----	



IES556 Shown

- Capacity ▶ 55 tons
- Stroke ▶ 6.25 - 13.25 in.
- Maximum Pressure ▶ 10,000 psi
- ▶ Large daylight with open sides for easy loading.
- ▶ Adjustable work bed with friction brake winch.
- ▶ Moveable work head for maximum versatility.
- ▶ Rigid frame under full load.
- ▶ IED & IES Series are equipped with a pendant control.

THINK SAFETY
Please refer to pages 4&5 for a complete list of safety tips and recommendations.

POWER PUMPS - pages 43 - 65
Simplex offers a wide variety of lightweight power pumps to fit any application.

PUMP MOUNTING KIT

For Hand PumpsModel IM2
Order # 40959

For Power PumpsModel IM3
Order # 40960

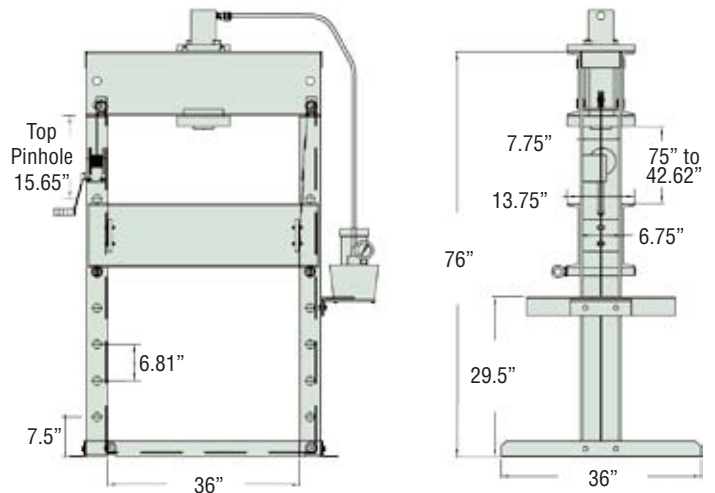

Hydraulic Presses

* For Presses with an electric 230V pump, add an "A" to the end of the model number.

Model Number Without Pump	* Model Number With Pump	Type of Cylinder	Cylinder Stroke (in)	Type of Pump	Pump Model	Operation	Speed (in/min) * Indicates Inches per Stroke		Weight With Pump (lbs)	Weight Without Pump (lbs)
							Advance	Pressing		
IS556	IES556	R556 S/A	6.25	Electric 115V	G1121	Advance Hold Retract	23	2	707	675
IS5513	IES5513	R5513 S/A	13.25		G1121		23	2	735	703
ID556	IED556	RDA556 D/A	6.13		G4172		35	5	748	710
ID5512	IED5512	RDA5512 D/A	12		G4172		35	5	793	755
----	IMS556	R556 S/A	6.25	Manual	P82A		.07*	.02*	711	----

HYDRAULIC PRESSES

100 Ton - H Frame

SIMPLEX



IES1006 Shown

Capacity Range► 100 tons
 Stroke► 6.06 - 12 in.
 Maximum Pressure► 10,000 psi

- Moveable work head for maximum versatility.
- Wide choice of pumps & pressing cylinders.
- Includes tonnage gauge.
- IED & IES Series comes with pendant control.
- Choose double-acting presses for fast retraction.
- Adjustable work bed with friction brake winch.

Hydraulic Presses



SIMPLEX CYLINDERS - pages 7 - 29
 Cylinder design specifications meet or exceed ANSI /ASME B30.1 Safety Standards.



POWER PUMPS - pages 43 - 65
 Simplex offers a wide variety of lightweight power pumps to fit any application.

PUMP MOUNTING KIT

For Hand PumpsModel IM2
 Order # 40959

For Power PumpsModel IM3
 Order # 40960

A machine shop needed to straighten forgings prior to machining and the Simplex 100 ton H Frame press was a perfect fit for the job. ▼

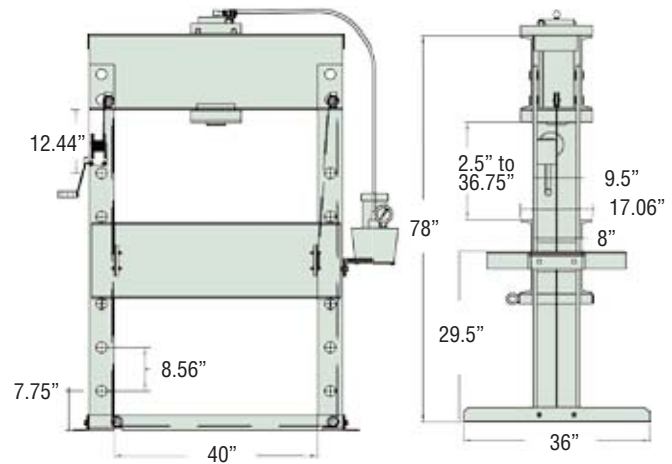

* For Presses with an electric 230V pump, add an "A" to the end of the model number.

Model Number Without Pump	* Model Number With Pump	Type of Cylinder	Cylinder Stroke (in)	Type of Pump	Pump Model	Operation	Speed (in/min)		Weight With Pump (lbs)	Weight Without Pump (lbs)
							Advance	Pressing		
IS1006	IES1006	R1006 S/A	6.62	Electric 115V	G4163	Advance Hold Retract	19	2.75	1558	1470
IS10010	IES10010	R10010 S/A	10.25		G4163		19	2.75	1578	1490
ID1006	IED1006	RDA1006 D/A	6.06		G4173		19	2.75	1620	1532
ID10012	IED10012	RDA10012 D/A	12		G4173		19	2.75	1655	1567



ID15012 Shown

Capacity ▶ 150 - 200 tons

Stroke ▶ 12 - 13 in.

Maximum Pressure ▶ 10,000 psi

- ▶ Large daylight with open sides for easy loading.
- ▶ Adjustable work bed with friction brake winch.
- ▶ Rigid frame under full load.
- ▶ IED Series comes with pendant control.
- ▶ Includes tonnage gauge.
- ▶ Presses ordered with pumps include remote pendant control and large 5 gallon reservoir.



THINK SAFETY

Please refer to pages 4&5 for a complete list of safety tips and recommendations.



GAUGES - page 77

Improve your system visibility and safety by adding an inline hydraulic gauge to your circuit.

PUMP MOUNTING KIT

For Hand Pumps Model IM2
Order # 40959

For Power Pumps Model IM3
Order # 40960

Rail car repair shops are constantly faced with large jobs, these applications require a reliable and safe high tonnage press. ▼

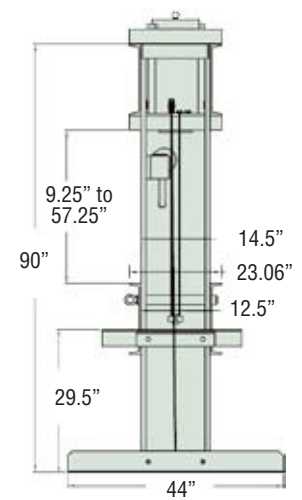
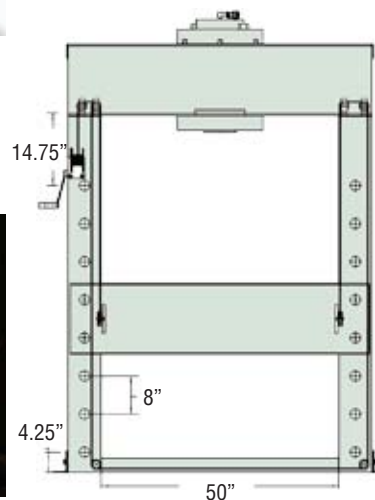

* For Presses with an electric 460V 3Ph pump, add an "A" to the end of the model number.

Model Number Without Pump	* Model Number With Pump	Type of Cylinder	Cylinder Stroke (in)	Type of Pump	Pump Model	Operation	Speed (in/min)		Weight With Pump (lbs)	Weight Without Pump (lbs)
							Advance	Pressing		
ID15012	IED15012	RDA15012 D/A	12	Electric 230V 3Ph	G6375	Advance Hold Retract	20	4.5	3035	2839
ID20013	IED20013	RDA20013 D/A	13				14	3.5	3180	2984